

D E U T S C H E S E L E K T R O N E N - S Y N C H R O T R O N

D E S Y

Hamburg-Gr.Flottbek 1, Flottbeker Drift 56

Lotkestieg 1

DESY-Notiz A 2.98

Hamburg, February 12th, 1963.

M 6-Be/P

"PRELIMINARY DESIGN OF SPECIAL MAGNET PULSING EQUIPMENT

FOR THE DESY ACCELERATOR"

by

Martin M. Berndt

The basic requirements for the equipment which is here described are formulated in a memorandum dated 26 Feb 1962 by Dr. F. Brasse. It is desired to be able to move the accelerated electron beam into a target inside the vacuum chamber by introducing a local distortion in the equilibrium orbit of the particles, at the point where the target is located. Certain selected magnets, fitted with additional windings for this purpose are to receive a pulse of controlled shape and magnitude which will produce a small change in the field of these magnets at the end of the acceleration cycle, and thus cause the orbit distortion.

According to the proposal of Dr. Brasse it will be necessary to pulse two magnets for each target, either two F magnets or two D magnets, depending on the location of the target. These two magnets receive identical pulses, and a third magnet, located between the other two magnets, receives a smaller pulse by means of which the angle of the emitted gamma ray is varied.

Table I lists the magnitude of the desired distortion at a point in the closed orbit, and the necessary ampere-turns required to produce this distortion at 7,5 GEV, as calculated by Dr. Brasse.

Table I: Pulse Data

| | Pulse applied to D magnets | Pulse applied to F magnets |
|---|-------------------------------|-------------------------------|
| Maximum orbit distortion | 3,5 cm | 5,5 cm |
| Bending angle at the pulsed magnet | 9,1 mrad | 3,4 mrad |
| Required ampere-turns in each of the outside magnets | 4600 at | 1100 at |
| Desired range of bending angle at center magnet | $\pm 2,5$ mrad | $\pm 1,2$ mrad |
| Resulting variation in angle of emitted gamma ray | $\pm 2,5$ mrad | $\pm 1,0$ mrad |
| Required ampere-turns in center magnet | 1050 at | 320 at |

The pulse is to have the general shape shown in Fig. 1. The peak value of the current is to be variable between $0,1 I_{\max}$ and I_{\max} , the rise time adjustable between $0,5 \text{ msec} < t_1 < 1,2 \text{ msec}$, and the duration

of the plateau adjustable between 0,2 msec $< t_2 < 1,2$ msec. The shape of the pulse during t_3 is not important. The shape of the plateau is to be adjustable to contain linear terms in t , as well as t^2 and t^3 . The pulse is to occur with a repetition frequency of 50 times per second. Variations between pulses are to be less than 0.5% of peak value.

The Pulsing Circuit

An analysis of the requirements for the most severe case, that of producing a pulse of 4600 ampere-turns in two D magnets, indicates that what is required to solve this problem is a circuit capable of delivering a pulse of a few hundred amperes at several kilovolts, the exact values depending on the number of winding turns and the winding location.

Three methods of generating such a pulse suggest themselves, two of which can be eliminated after just a quick thought process.

As a first possibility one may consider a circuit in which a capacitor of the appropriate size is charged to the required voltage, and then discharged into the magnet winding by means of a thyatron. The duration of the current pulse depends on the resonant frequency of winding inductance and storage capacitance, and is such that at the end of the pulse the capacitor is charged to about the same voltage, but in opposite direction. Using another thyatron in an antiparallel connection to the first thyatron, the capacitor is discharged again and then recharged to its original polarity. In this manner most of the energy is recovered, except for circuit losses.

This scheme, though simple, presents several problems. Chief among them is that it allows for no control of the shape of the pulse, particularly in the plateau where control is needed. The pulse width can only be varied in steps, by adding or subtracting capacitors that change the resonant frequency. Finally, the magnitude of the pulse is determined not only by the voltage on the capacitor, but also by the timing of the pulse, since the voltage induced into the pulse winding by the main magnet current also must be considered. Thus the use of such a

circuit was eliminated because of its lack of flexibility.

A second scheme was considered, but also had to be eliminated. A high frequency alternator is driven by a motor, and the output is rectified by means of thyratrons or ignitrons. By adjusting the firing angle of the thyratrons it is possible to obtain a series of rectified pulses with an envelope of the desired shape. Most of the energy needed for the pulse is recovered at the end by delaying the firing angle of the thyratrons. The rotating mass of the motor and generator serve as the necessary energy storage device. The scheme is basically the same as that employed in the main power supplies of accelerators such as the PS at CERN.

Unfortunately the duration of the pulse is too short to make such a scheme practical. Whereas for the PS at CERN the duration of the pulse is about two seconds, the pulse here considered is about one thousand times shorter. It would be necessary to use a three-phase alternator operating at about 20,000 cycles, and with 20 KVA capacity; this borders on the practical. A more serious problem exists in finding thyratrons with short enough deionization times; none were available.

The third scheme is somewhat expensive and wasteful of power. But it is the only workable one, and is also capable of meeting the necessary requirements of control, flexibility and accuracy. The energy required for the pulse is stored in a capacitor bank which is recharged between pulses by a power supply. The capacitors are discharged into the magnet winding by means of power triodes in which the grid voltage is controlled in such a manner that a pulse of the proper form and amplitude results. All energy is dissipated in the tubes, and none is recovered at the end of the pulse. Details of the circuit are discussed in the following.

Block Diagram and Proposed Circuits

Figures 2 and 3 show the power amplifier stage of the pulser, and Figure 4 is a block diagram of the complete system. The F magnet pulser is basically the same as the D magnet pulser, with the final

stage in the power amplifier removed. Each power amplifier is designed to drive two magnet windings in series. The same pulser may also be used to power the third or single magnet for the small adjustments in the angle of the beam.

Though the circuit may at first seem somewhat complicated, the reason for its choice lies in the limitations imposed on the insulation of a practical winding. Since it is desirable to keep the voltage from winding to ground to a minimum, it is necessary to ground the circuit at the midpoint between the two windings which are connected in series; the voltage from winding to ground is then only one-half of the total winding voltage, not in excess of a few kilovolts. A current shunt, which is necessary for measurement and for the feedback operation, can be placed at ground potential in series with the winding. A complication introduced by grounding the circuit at this point lies in that the storage capacitors (C_1 and C_2 for the D magnet pulser and C for the F magnet pulser), as well as all the power supplies, power tubes and driver circuits must be isolated from ground for the full potential of the power supply output voltage plus any induced voltages resulting from the main magnet current. Though inconvenient, this is not impossible, as the maximum voltage in the worst case is about 15 KV.

The circuit functions as follows. A pulse is originated at ground potential, its shape the result of the amplified difference between an input pulse of the desired shape, and the feedback signal derived from the shunt. The pulse is then used to modulate a carrier system operating at a frequency of perhaps around 5 megacycles, which is transformer coupled into the power amplifier stage. Coupling of the signal into the power amplifier by means of an r-f transformer permits grounding of the complete preamplifier circuitry, and isolating it from the input to the power amplifier which is at a changing high potential. The modulated r-f signal is demodulated by the rectifier, and fed to the grid of the first power tube, a Siemens RS 2011 triode. This triode, which operates as a noninverting amplifier, drives the next stage, a Siemens RS 2001 triode. The circuit ends at this point for the F magnet pulser, whereas for the D magnet pulser the RS 2001 simply serves as a direct coupled cathode follower to drive the next and final stage, two Siemens RS 1041

operating in parallel. The energy for the pulse is obtained from a capacitor bank which is recharged between pulses.

There are two features about this circuit which result in an efficient and useful design. One is the manner in which the RS 2001 and the RS 1041's are connected, with the result that the entire current drawn by the RS 2001 is added to the anode current of the RS 1041's to appear as load current in the winding; the current of the RS 2001 is appreciable because of the large positive grid drive necessary to operate the 1041's. The net result is a conservative operation of the final stage, and a reduction in the size of the power supply. The other feature is the selection of the anode voltage supply for the RS 2011; it was chosen just large enough so that this stage would operate at negative grid potentials throughout the length of the pulse, with a resultant saving in the required strength of the input r-f pulse.

The Special Magnet Winding

The choice of the type of winding to be used was arrived at after a compromise between several factors. Among these factors were such things as the available space for the winding, the required insulation, the necessary wire cross-section, cooling requirements, and peak current demands to fit those of available power triodes.

Originally it was thought to simply wind several turns around the back legs of the magnets. Later measurements revealed that a winding constructed in this manner has a considerably larger inductance than that calculated on the basis of the inductance of the main windings which are placed near the airgap; the source of the higher inductance of the backleg winding is the leakage flux around the outside of the magnet, which exists in addition to the flux across the gap. In the F magnets the back leg winding can be built up in the form of two layers of an insulated wire with an outside diameter of about 8,5 mm; the space available for this purpose is sufficient, while still permitting easy removal and installation of the vacuum chamber. In the D magnets the back leg winding can be built up of several layers of an insulated wire with an outside diameter of

about 16 mm.

As an alternative to the backleg winding, Dr. Hardt at DESY has investigated the construction of a specially made winding in the form of two thin sheets that are placed between the two main magnet windings, both above and below the airgap (DESY Spez. B 2.163). This results in a winding with lower inductance than a backleg winding, although it is somewhat more costly. The advantage of the lower inductance is that for a given voltage it is possible to obtain a faster rise time at the beginning of the pulse.

At this time plans are to use backleg windings initially for both F and D magnets. If the advantages of the special airgap winding over a backleg winding in allowing for a faster pulse rise time are considered important enough, the special windings will be installed at a later date.

Data pertinent to the windings are listed in Table II. An explanation of the meaning of the different voltages mentioned in the table is illustrated by Fig. 5. Since the pulse occurs near the end of the acceleration cycle, the voltage peak fortunately occurs at a time when the voltage induced by the 50-cycle main magnet current is near zero. The resultant peak voltage to which the winding is subjected is the sum of the pulse voltage plus the instantaneous 50-cycle voltage. It is seen from the data that this sum is lower than the peak induced 50-cycle voltage for the F magnets, but is larger for the D magnets.

The electrical equivalent circuit of the magnet with its windings is shown in Fig. 6. The magnet may be thought of as an ordinary transformer, in which the magnetizing impedance, usually quite large, is in this case relatively small because of the magnet airgap. The relative distribution of the leakage reactance is understandable, since a winding near the airgap, such as the main windings, produces less leakage flux than a winding around the magnet back legs. If instead of the backleg winding the special airgap winding is used, then the equivalent circuit changes in that the leakage reactance shown for the backleg winding is practically eliminated; main winding and pulse winding will then be very closely coupled.

Table II: Magnet Winding Data.

| | <u>D Magnet</u> | | <u>F Magnet</u> | |
|---|---|---------------------------|---|---------------------------|
| | <u>Backleg Winding</u> | <u>Airgap Winding</u> | <u>Backleg Winding</u> | <u>Airgap Winding</u> |
| Number of turns per magnet | 15 | 15 | 20 | 20 |
| Inductance per magnet | 7,0 millhy | 4,1 millhy | 15,9 mhy | 10,9 mhy |
| Peak pulse current | 307 amp | 307 amp | 55 amp | 55 amp |
| RMS value of a 3,6 msec long trapezoidal current pulse (1,2 msec rise and fall, flat top) | 97 amp | 97 amp | 17.4 amp | 17.4 amp |
| Peak pulse voltage (for 0.5 msec linear rise time) | 4290 v/mag | 2500 v/mag | 1750 v/mag | 1180 v/mag |
| Peak 50 cycle voltage induced by main magnet field | 2550 v/mag | 2550 v/mag | 3200 v/mag | 3200 v/mag |
| Peak total voltage (induced plus applied) if pulse starts 1 msec before peak of fluxwave | 5080 v/mag | 3340 v/mag | 2740 v/mag | 2170 v/mag |
| Wire type and cross-section | Copper 35 mm ² | Copper -- | Copper 10 mm ² | Copper -- |
| Insulation | Special rubber type NSGAF (100°C) -- 16 mm OD | -- | Special rubber type NSGA (100°C) -- 8,5 mm OD | -- |
| Winding resistance | 0.073 ohm at 20° C | -- | 0.32 ohm at 20° C | -- |
| Manner of cooling | Convection and contact with iron and main winding | Contact with main winding | Convection and contact with iron and main winding | Contact with main winding |
| Estimated winding hop-spot temperature | 75° C | -- | 60° C | -- |

The circuit constants for the equivalent circuit were obtained from open and short-circuit tests; the presence of the small "negative" terms for the D magnet main winding leakage reactance cannot be entirely explained by measurement errors, but is negligibly small anyway (it can perhaps be accounted for by turn to turn capacitance in the circuit connection used in the tests). The equivalent circuit is especially useful in determining the behavior of the pulser in the case of abnormal operation, such as a short-circuit resulting from an arcover in the power tubes.

The Power Amplifier Tubes

The final stage of the D magnet pulser will consist of two Siemens RS 1041 tubes operated in parallel. The peak emission current for these tubes (anode plus grid current) is given as 190 amperes, and the anode to cathode voltage is conservatively listed as 15 kilovolts. In actual operation the peak anode current will be about 130 amperes per tube, while the remainder of 47 amperes (total pulse current of 307 amperes) is supplied by the cathode follower coupled driver type Siemens RS 2001. Equal division of the current between the two RS 1041's is assured by the use of 4-ohm grid resistors, a solution made possible by the fact that the output tubes require a strong positive grid drive to obtain the high anode current. The final stage of the F magnet pulser consists of a single Siemens RS 2001 triode, which at 55 ampere peak current will operate well below the peak emission of 100 amperes; it is also rated for an anode to cathode voltage of 15 kilovolts. In all cases tube grid dissipation should be well below its rated maximum.

It is intended to use watercooled tubes. The use of vapor-cooled tubes is not warranted; the additional expense of a vaporcooled installation becomes worthwhile only if the heat produced can be reused in some other manner and if there exist special cooling problems. Applicable cooling data is listed in Table III.

Although it is preferable to use only distilled water to cool the power tubes, in this case it is intended to use, at the beginning at least, the available demineralized water available for experiments. At a later date, if necessary, a closed distilled water system with pump

Table III: Tube Cooling Data

(A) Estimated cooling requirements for D magnet pulser

| | |
|--|------------------------------|
| Maximum anode dissipation for each RS 1041 | 78 kilowatts |
| Maximum anode dissipation for RS 2001 | 24 kilowatts |
| Maximum anode dissipation for RS 2011 | 6 kilowatts |
| Filament dissipation for each RS 1041 | 5,0 kilowatts |
| Filament dissipation for RS 2001 | 3,0 kilowatts |
| Filament dissipation for RS 2011 | 0,7 kilowatts |
| Total dissipation | 199,7 or about 200 kilowatts |
| Incoming water temperature | 30° C |
| Outflowing water temperature | 45° C |
| Water quantity for each RS 1041 | 4.76 m ³ /hour |
| Water quantity for RS 2001 | 1.55 m ³ /hour |
| Water quantity for RS 2011 | 0.38 m ³ /hour |
| Total water | 11,45 m ³ /hour |

(B) Estimated cooling requirements for F magnet pulser

| | |
|--------------------------------------|----------------------------|
| Maximum anode dissipation of RS 2001 | 20,0 kilowatts |
| Maximum anode dissipation of RS 2011 | 6,0 kilowatts |
| Filament dissipation of RS 2001 | 3,0 kilowatts |
| Filament dissipation of RS 2011 | 0,7 kilowatts |
| Total dissipation | 29,7 or about 30 kilowatts |
| Incoming water temperature | 30° C |
| Outflowing water temperature | 45° C |
| Water quantity for RS 2001 | 1,34 m ³ /hour |
| Water quantity for RS 2011 | 0,38 m ³ /hour |
| Total water | 1,72 m ³ /hour |

and heat exchanger may be installed. Isolation between power tubes at high electrical potential and ground will be provided with hose of insulating material.

The Siemens type RS 1041 water cooled tube is identical to the Telefunken type RS 567, and the Siemens RS 2001 is identical to the Telefunken RS 565. No particular reason exists for the choice of the Siemens tubes over the Telefunken tubes, except that it was thought advisable that all tubes should be furnished by one and the same manufacturer. Triodes from several other manufacturers were considered also, but were eliminated because of price or technical considerations (Thomson Houston TH 478, M.O. Valve Co. CAT 27, RCA Developmental Type A 15034, Machlett ML 6696).

Filament Transformers

The filaments of the power tubes will be heated with alternating current. The cathodes are made of Thoriated Tungsten, with a resistance at room temperature which is as much as seven times lower than the resistance at the operating temperature. Thus when filament power is first turned on, there is a large inrush of current, which it is desirable to reduce in spite of the manufacturer's claim that it has no adverse effects on the life of the tube. The filament transformers that have been selected have a leakage reactance which limits their short circuit current to about six times their rated current, so that the filament starting current should not be more than about four to five times its normal value. The transformers are provided with taps of $\pm 8\%$, $\pm 5\%$, and $\pm 2\%$ on the primary to permit selection of the proper voltage, so that the normal filament operating current will not be exceeded. It is intended to operate these transformers directly off the 220 volt unregulated distribution system. Only if line voltage disturbances prove to be excessive will it be necessary to precede the transformers with line voltage regulators.

In the event that the transformer leakage reactance should present too large an impedance to the pulse, it will be necessary to connect paralleling resistors between the centertap and each of the outside terminals of the transformer winding; resistors of about one ohm should

suffice, without appreciably increasing the load on the transformers.

Grid Bias Power Supply

The circuit diagram for the grid bias supply is shown in Figure 7. With a single power supply it will be possible to provide the two different grid bias voltages for both the RS 2001 and RS 1041 stages.

The design of the power supply is straightforward. A line voltage regulator serves to stabilize the incoming line. The rectifier transformer as well as the entire output is isolated for 15 kilovolts DC. The rectified and filtered output voltage may be adjusted by means of the rheostats. The complete supply is designed to be short-circuit proof, with coordinated fuse and circuit-breaker protection.

Pulse Power Supply for the Preamplifier RS 2011

The specifications for this power supply are outlined in DESY Spez. B 2.145 and B 2.156 (part A). The same type of power supply is to be used for both the F magnet and the D magnet pulsers. The power supply is rated at 5 KV and 6 KW, and the storage capacitors are 40 microfarads at a maximum normal operating voltage of 5,3 KV.

The energy storage capacitor was chosen large enough so that for the duration of the pulse the voltage across the tube would never drop so low that the tube would be required to draw grid current. The average capacitor voltage was chosen with the same thought in mind.

The energy taken from the capacitor during the pulse is supplied between pulses by a choke filtered power supply. The design of the power supply proceeded on the basis of theory similar to that outlined in the Cambridge report CEA No. 68. The power supply voltage is given by the average of maximum and minimum capacitor voltages, and the size of the filter choke is selected so as to keep the line current fluctuations below some arbitrary and reasonable limit ($I_{\text{peak}}/I_{\text{ave}} = 1,11$).

The power supply is a three-phase bridge rectifier circuit. It is designed to be short-circuit proof, to account for the possibility of a breakover in the tube. It has an adjustable output. The entire high

voltage side of the power supply is to be insulated for 15 KV DC to ground.

Main Power Supply for the F Magnet Pulser

The specifications for this power supply are outlined in DESY Spez. B 2.156 (Part B) and B 2.157. The power supply is rated at 3 KV and 20 KW, and the storage capacitors are 40 microfarads at a maximum normal operating voltage of 4,65 KV.

The design of this power supply and capacitor storage bank proceeded on a basis similar to that for the preamplifier power supply. The important consideration here was to have available at the beginning of the pulse a voltage large enough to allow for even the fastest pulse rise time. The size of the capacitor was chosen large enough so that even for the longest pulse the voltage across the tube near the end of the pulse would not drop below some desirable value. The power supply used to charge the capacitor is a filtered three phase bridge rectifier power supply, short circuit proof, and insulated for 15 kilovolts DC.

The capacitor and tube (RS 2001) voltage waveforms are shown in Figure 8. The tube voltage drop includes the voltage drop across the small resistors in series with the tubes. Three cases are shown for pulses with three different rise times, 0,5 msec, 0,7 msec, and 1,2 msec. The plateau is assumed flat and lasting 1,2 msec, and the cutoff is assumed to occur in a manner similar to the start of the pulse. The voltage across the tube is the sum of the capacitor and the winding voltage; while the pulse current is rising the winding voltage is of such a polarity that the resulting tube voltage is reduced by the amount of the winding voltage, whereas at the end of the pulse, when the current is falling, the winding voltage is added to the capacitor voltage to yield the tube voltage.

As can be seen from Figure 7, it will not be possible to obtain pulse rise times of 0,5 msec if the high inductance backleg winding is used; a pulse rise time of 0,7 msec is about the limit. If the special sheet windings near the airgap are used, then it will be possible to obtain rise times of 0,5 msec.

In all calculations for the waveforms of Figure 7 the effect of the 50 cycle induced voltage wave is not shown. This effect depends on the direction of the pulsed bump (whether the pulse current is to increase or decrease the magnet flux), and on the time considered (whether before or after the instant at which the induced voltage wave goes through zero). In general, the pulse is to occur at the peak of the magnet flux wave, centered about the instant when the induced voltage wave is near zero. Since the two magnet windings connected in series are pulsed in the same direction, the effect of the induced voltage from both magnets is additive. The most unfavorable case occurs when it is desired to increase the magnet flux by means of the pulse; in this case the winding voltage necessary to obtain the desired current pulse must be increased by the instantaneous value of the 50 cycle voltage wave; this increase can only come from a reduction in the tube voltage at that instant. At the end of the pulse the effect of the induced voltage is the opposite, and for the above mentioned case, the instantaneous induced voltage is added to the tube voltage. To assure adequate circuit performance throughout the pulse it will be necessary in actual operation to make minor adjustments both in the timing of the pulse and in the waveform of the voltage rise; for pulses that are to start too soon before the peak magnet flux has been produced, it may not be possible to obtain the extremely short rise times or the full pulse amplitude.

Main Power Supply for the D Magnet Pulser

The specifications for this power supply are outlined in DESY B 2.127, B 2.128, B 2.129 and B 2.130. It consists of two units: a 6 KV/90 KW power supply with a capacitor storage bank of 40 microfarads at a maximum normal operating voltage of 9,75 KV, and a 3 KV/90 KW power supply with a capacitor storage bank of 400 microfarads and a maximum normal operating voltage of 3,75 KV.

The design of this power supply proceeded on similar criteria to that used in the design of the F magnet power supply. Economical operation so as to reduce power consumption was much more important in this case, hence the design chosen.

An examination of the tube voltage waveforms for a power supply such as used for the F magnet pulser shows that during operation the tube voltage at the beginning of the flat portion of the pulse is unnecessarily large, with the result that power consumption is increased. Unfortunately the capacitor voltage must be large at the beginning of the pulse to permit both the fast pulse rise time and to prevent the tube voltage from dropping too low near the end of the pulse. The use of two power supplies with a paralleling diode as shown in the D magnet pulser seeks to solve this problem and to reduce power consumption. At the beginning of the pulse the current is supplied by the small capacitor charged to a high voltage. As the voltage on this capacitor is reduced because of the charge removed by the action of the current, a point is reached at which its voltage is equal to that of the large capacitor charged to a lower voltage. Both capacitors begin then to operate in parallel through the action of the diode between them; during the early portion of the pulse the diode is backbiased and of course does not conduct. The net result is a supply voltage which is relatively "soft" at the beginning of the pulse, and "stiff" during the flat portion of the pulse. If in addition the current wave during the pulse rise time is not made linear but more nearly sinusoidal, then a condition can be reached in which the tube voltage will remain nearly constant.

An even more sophisticated alternative would replace the large capacitor at low voltage with a lumped parameter transmission line, which would yield a pulse with a duration equal to the length of the flat top of the current pulse. Thus it would be possible to reduce power consumption during the final part of the current pulse, when it is desirable that the supply voltage be kept as small as possible, since it is added to the winding voltage which results from the decay of the pulse. Such a solution is not contemplated at present, although it would not be difficult to modify, if desirable, the large capacitor and its associated filter choke; the capacitor bank which will be used consists of ten equal sections which could be used to build up a lumped parameter transmission line.

The magnitude of the saving achieved by a design such as proposed is illustrated by the following comparison, which lists the capacity of different types of power supplies needed to obtain a current pulse

in two series connected airgap windings for D magnets. The values listed represent minimum values, arrived at by setting some arbitrary lower limit below which the tube voltage should not drop, either for the longest pulse or for the pulse with the fastest rise time. All the power (except for small winding losses) is dissipated in the tubes.

A single fixed voltage (zero internal impedance) power supply delivering a trapezoidal pulse (3,6 msec long) with linear rise and fall 276 KW

A single capacitor (95 microfarads charged to 8,3 KV) delivering a trapezoidal pulse (3,6 msec long) with linear rise and fall 164 KW

A two unit power supply (45 microfarads charged to 7,73 KV and a 2,5 KV power supply with zero internal impedance), delivering a pulse (3,6 msec long) with linear rise and fall 135 KW

A two capacitor power supply (45 microfarads at 7,73 KV and 736 microfarads at 3 KV) delivering a pulse (3,6 msec long) with sinusoidal rise and fall 138 KW

A two unit power supply (45 microfarads at 7,73 KV and a lumped parameter transmission line for a 1,2 msec long pulse at 2,5 KV) delivering a trapezoidal pulse (3,6 msec long) with sinusoidal rise and linear fall 106 KW

The saving in power consumption, even if not particularly impressive, is sufficient to warrant the use of a two unit power supply. The reduction in the size of the power supply becomes more pronounced for a larger inductance such as a back leg winding instead of an airgap winding. As usual, the design chosen was the result of a compromise between many factors, allowing at the same time for sufficient reserve capacity.

The paralleling diode between the two capacitors must be able to pass relatively large peak currents (307 amp) with a small voltage drop; its average current rating does not have to be very large, except that, as shown later, it must be able to withstand high short circuit currents (2500 amp) in the event of a breakdown in the tubes. Silicon rectifier diodes will meet this demand. It is intended to use a string of 15 Semikron Type SK 100/12 silicon diodes (120 amp ave, 770 PIV repetitive, and 3000 amp surge for 10 msec) as a paralleling

diode, as well as a string of 6 similar diodes for the protection of the large capacitor bank.

The calculated capacitor and tube voltage waveforms during the duration of the pulse are shown in Figure 9. The same comments made in the discussion of the F magnet pulser regarding the effect of the induced voltage from the 50 cycle main magnet current also apply here.

Protection Circuits

One of the most important and most difficult problems in installations such as this one involves the protection of the equipment in the event of a breakdown or arcover in the triodes. The conventional technique used is to apply a short circuit or a "crow bar" across the tube or the storage capacitors within microseconds after the breakdown has occurred, so as to bypass the short circuit current around the tube and to prevent its destruction. The problem in this application is made more difficult by the presence of two sources of energy which can feed a short circuit, one the storage capacitor, the other the magnet or load winding itself which is coupled to the main magnet winding, and is effectively equivalent to a transformer.

In order to estimate how large the current in a short circuit can be, certain simplifying assumptions are made. The entire circuit is represented by an ordinary RLC series circuit driven by an alternating voltage source, with initial conditions that depend on the time at which the short occurs and the capacitor voltage at that instant. The complications are twofold, first that the capacitor is nonlinear because of the presence of the diodes, and secondly that the magnitude of the current in the first moments after the short appears depends on the time at which the short occurs. A point by point calculation was made for what was considered to be the most likely time at which a tube breakdown would occur, that is, when the tube voltage is at its maximum; this occurs when the capacitors are charged to their full voltage and the 50 cycle voltage induced by the main magnet current is at a maximum. The calculations revealed that during the first nine milliseconds after the short occurs the current looks approximately like a half sinewave, with a peak of about 2500 amperes; other pulses of approximately the

same amplitude continue to occur at 20 millisecond intervals until the circuit is either opened or all power is removed. Moreover, it was shown that the large capacitor, unless it is protected in some manner, would be charged to a voltage far in excess of its rating and in a direction opposite to its normal polarity.

Three things are necessary to provide short circuit protection in this case: The large capacitor must be protected, the short circuit current must be bypassed around the tube, and the circuit itself must be opened so that the short will not continue to be fed by the transformerlike magnet winding.

The protection of the capacitor is accomplished easily enough by placing a diode parallel to it; the diode must be capable of carrying the large short circuit pulse, hence will consist of a string of six diodes of the type Semikron SK 100/12, as mentioned earlier.

The tube in which the breakdown has occurred may be protected by a "crow-bar" circuit, a thyatron of the type BBC TQ 8 which is connected parallel to the tube. The low voltage drop across the thyatron during conduction should assure extinction of the arc in the tube by starving it of voltage; to insure that the fault current will flow in the thyatron rather than the tube, a resistance of up to two ohms may be connected in series with each tube (a larger resistor would waste too much power and excessively reduce tube voltage during normal pulsed operation). The thyatron must be triggered by a circuit which senses the collapse of the voltage across the tube; the conventional technique of triggering the thyatron or "crow bar" by sensing the rate of rise in the current after a short has occurred cannot be used here because the winding inductance limits the rate of rise to a value not much different than that which exists during normal operation. Unfortunately it is not possible to protect the tube by placing the "crow bar" across the capacitor instead of the tube, since the tube short circuit would still continue to be fed by the transformerlike magnet winding; it is necessary to short out both the capacitor and the winding.

The solution presently envisioned for the last problem, that of

opening the circuit, is not entirely satisfactory. It is necessary that the circuit be opened because although the power supplies used to charge the capacitor can be disconnected, interruption of the main magnet current in case of such a breakdown is out of the question. The switch or circuit breaker for opening the circuit must be able to carry a peak current of 2500 amperes, withstand about 15 KV DC, and interrupt the current not later than 9 milliseconds after the short has occurred, in other words not later than the end of the first large current pulse. Most high voltage fuses are too slow for this purpose. It is conceivable that a vacuum switch may be built which will meet the requirement. A somewhat extravagant but workable solution would be the use of an explosive current interruptor such as is manufactured by Calor Emag (I_s Begrenzer).

Construction Plans

It is intended to build the F magnet pulser first, because of its smaller size. The power supplies and various components have already been ordered. Instead of the main power supply for the F magnet pulser described earlier, the high voltage unit for the D magnet pulser has been ordered; it will simply be operated at a reduced voltage, thus allowing last minute modifications to be made on the specifications for the F magnet pulser power supply, if shown advisable during operation.

The design of the r-f pulse modulator and of the pulse waveshape generator (see block diagram, Fig 4) has not yet been done; it is not expected that this should present any great problems, because such circuits are fairly conventional.

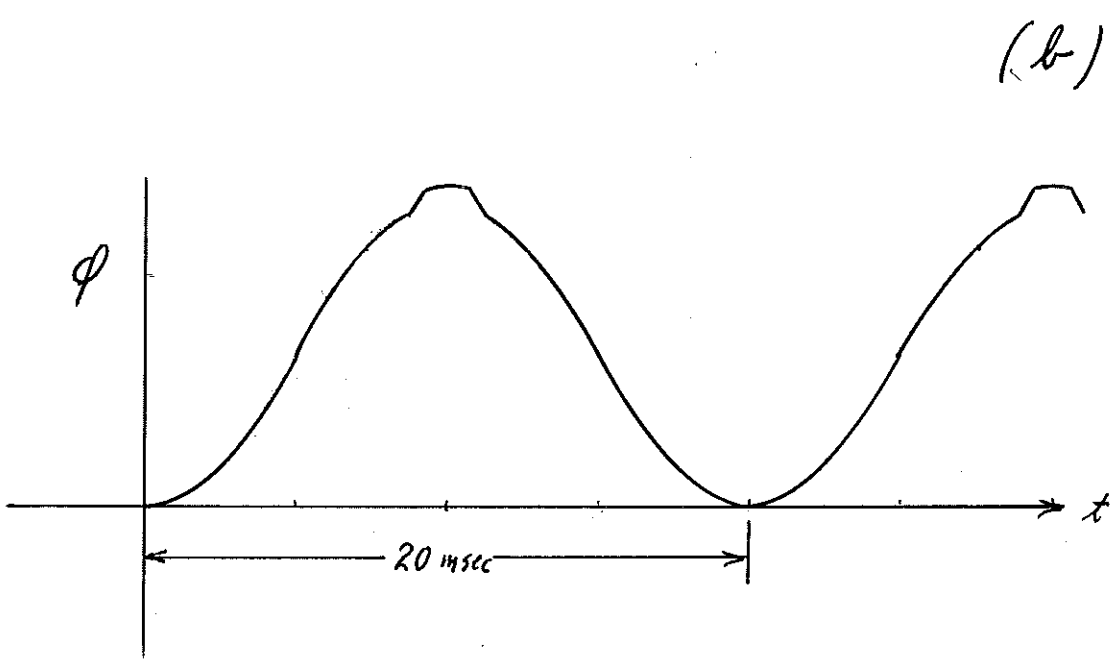
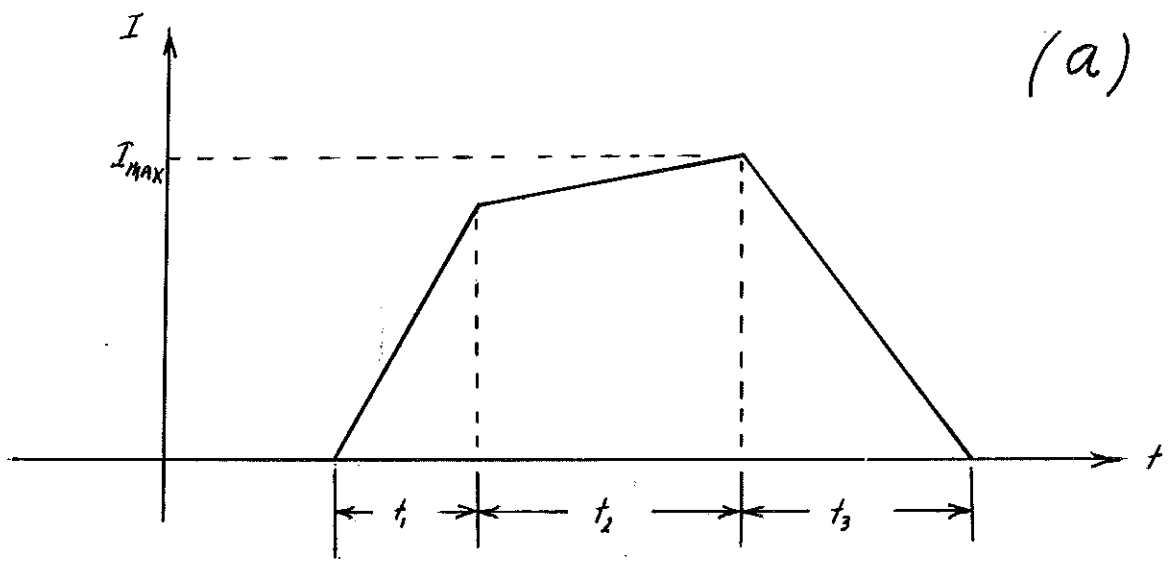

Figure 1: a) Pulse wave shape
b) Flux in pulsed magnet

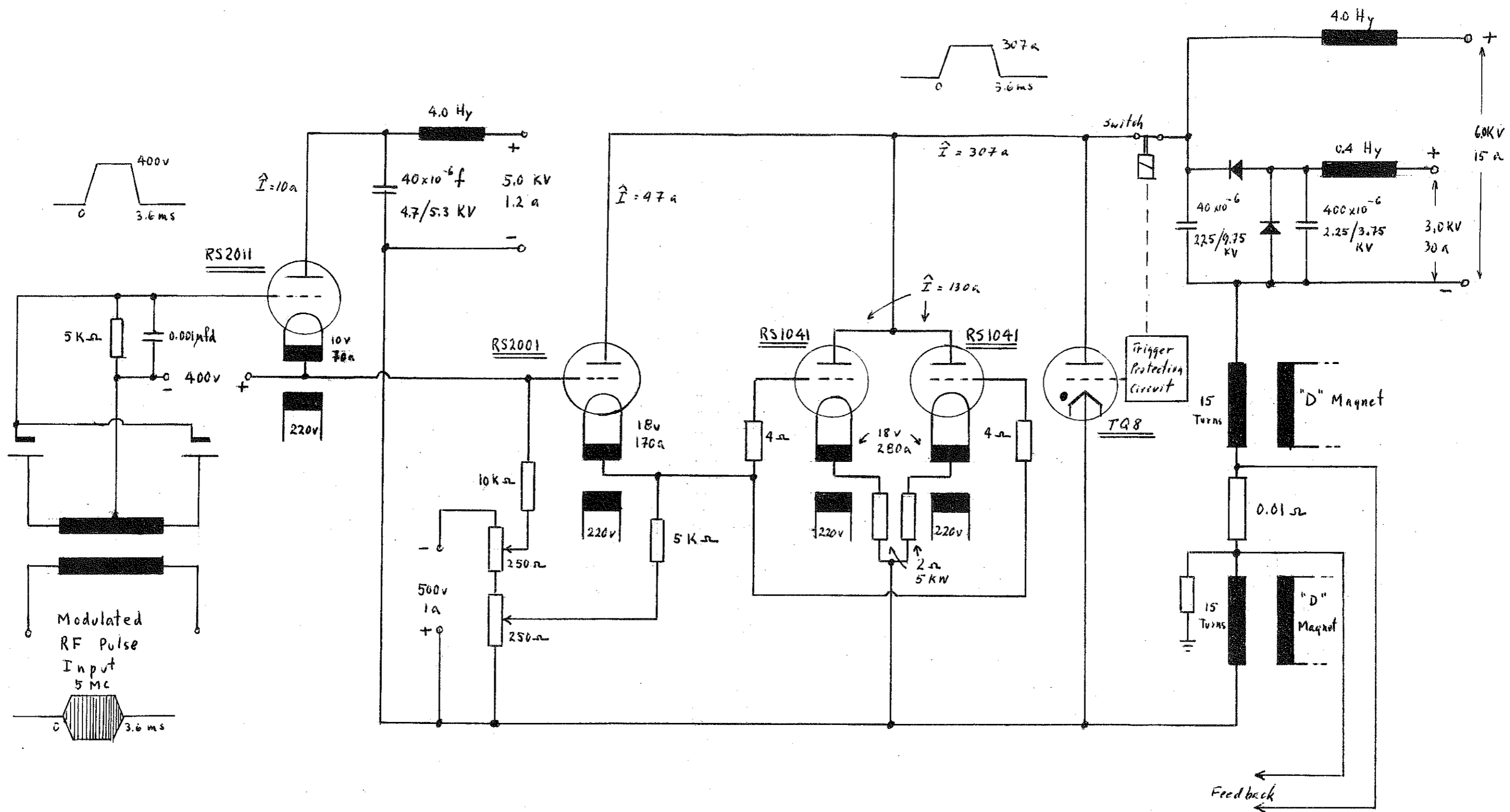

Fig. 2 : "D" Magnet Pulser

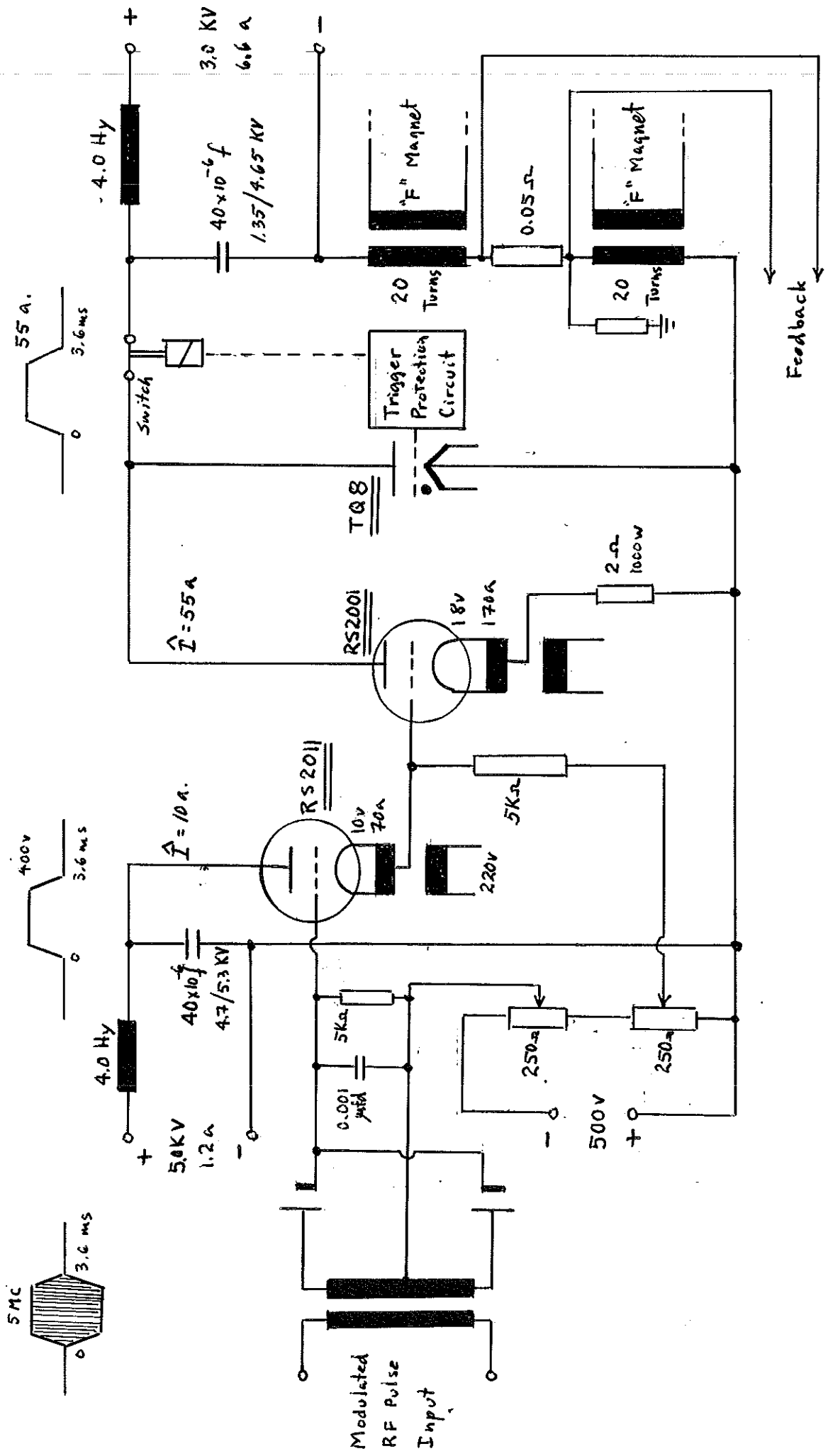

Fig. 3: "F" Magnet Pulser

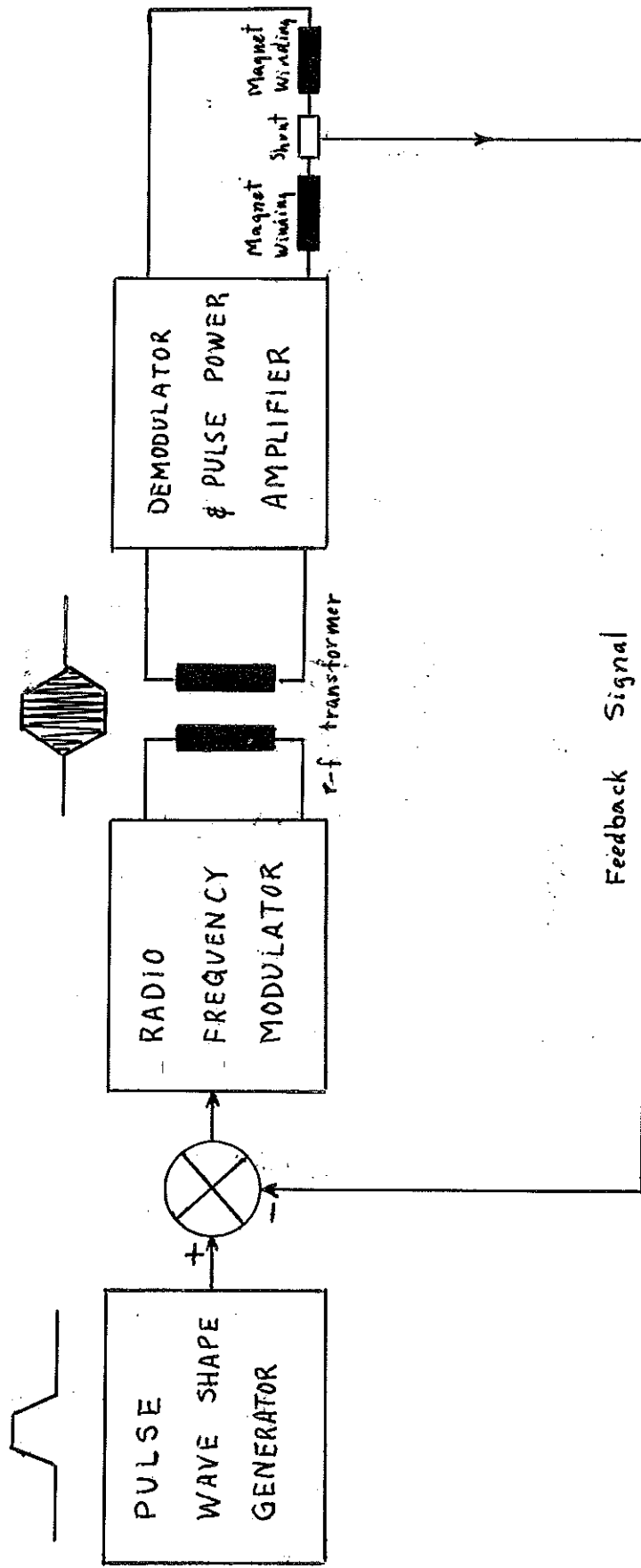

Figure 4: Block Diagram of a Pulser

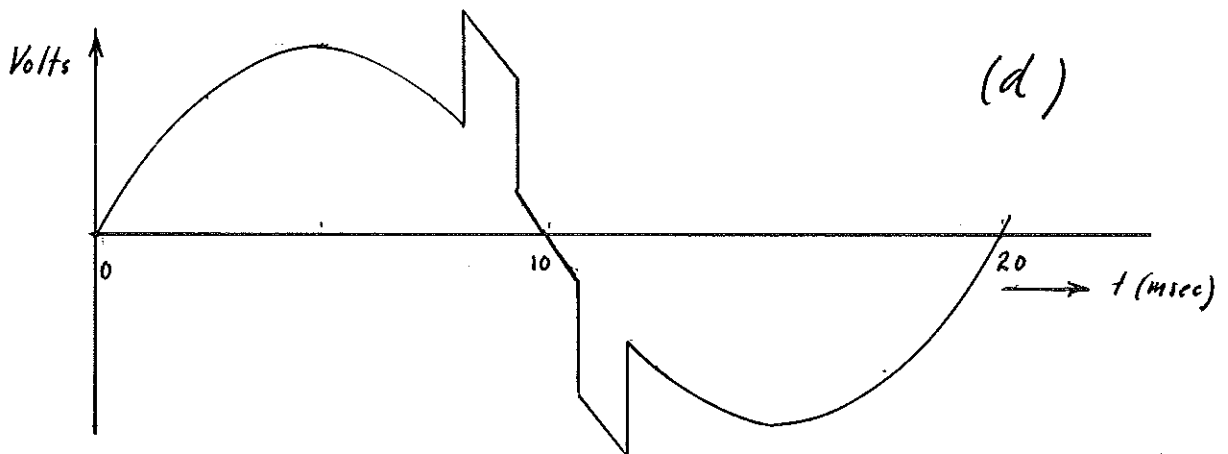
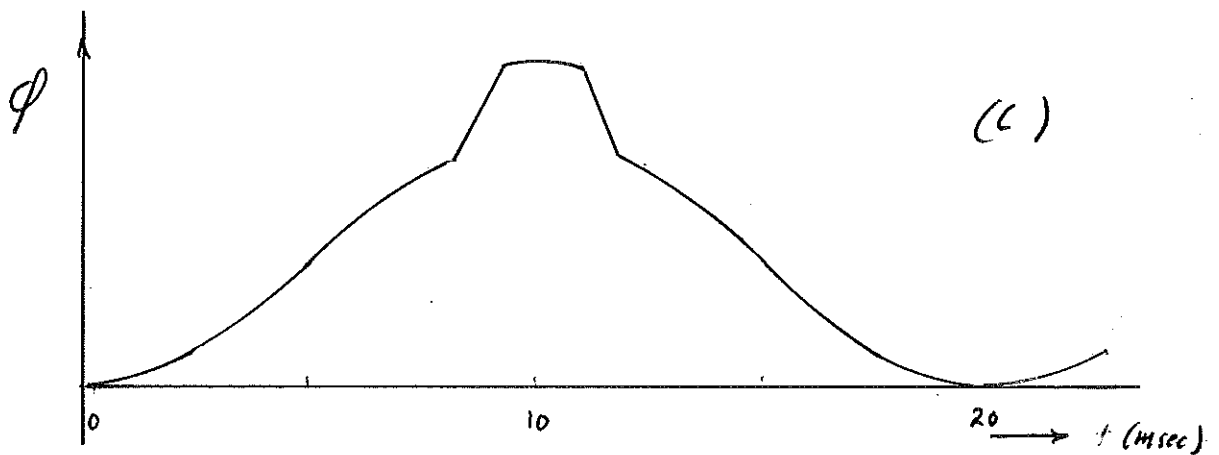
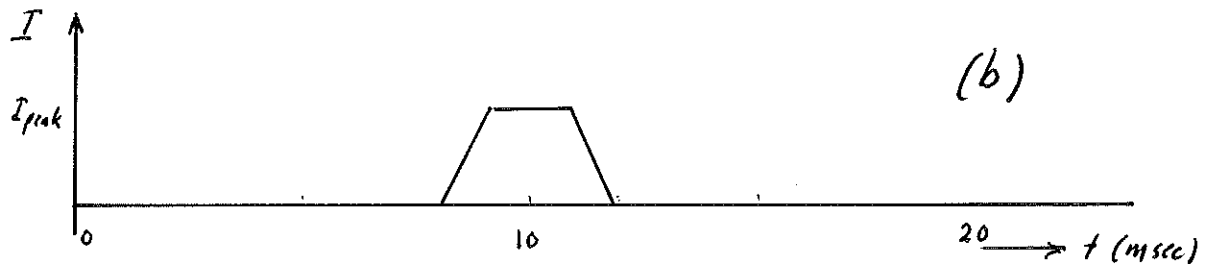
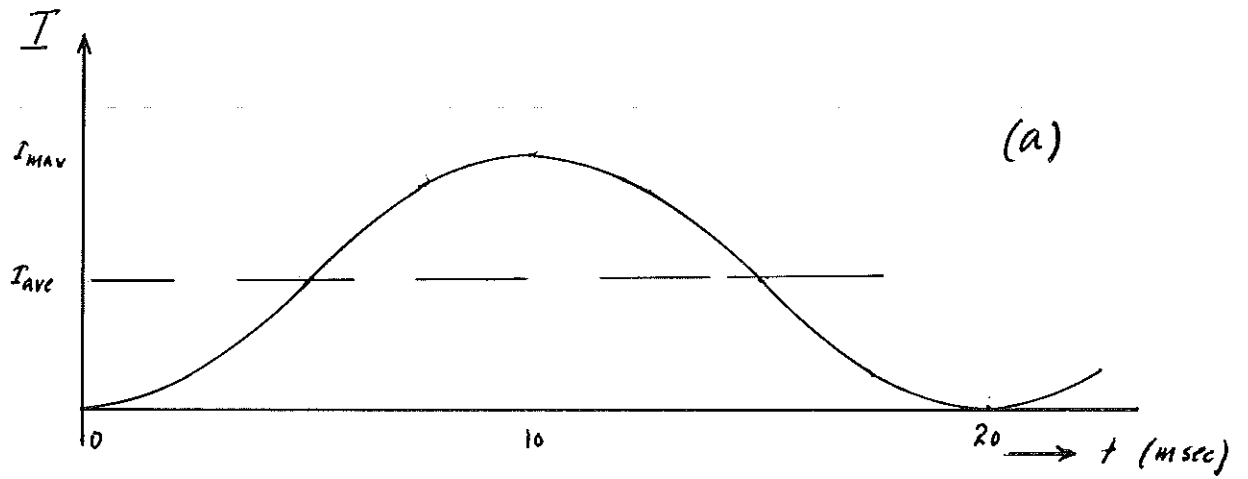

Fig. 5: a) Main magnet winding current
 b) Pulsed winding current
 c) Magnet flux
 d) Magnet winding voltage

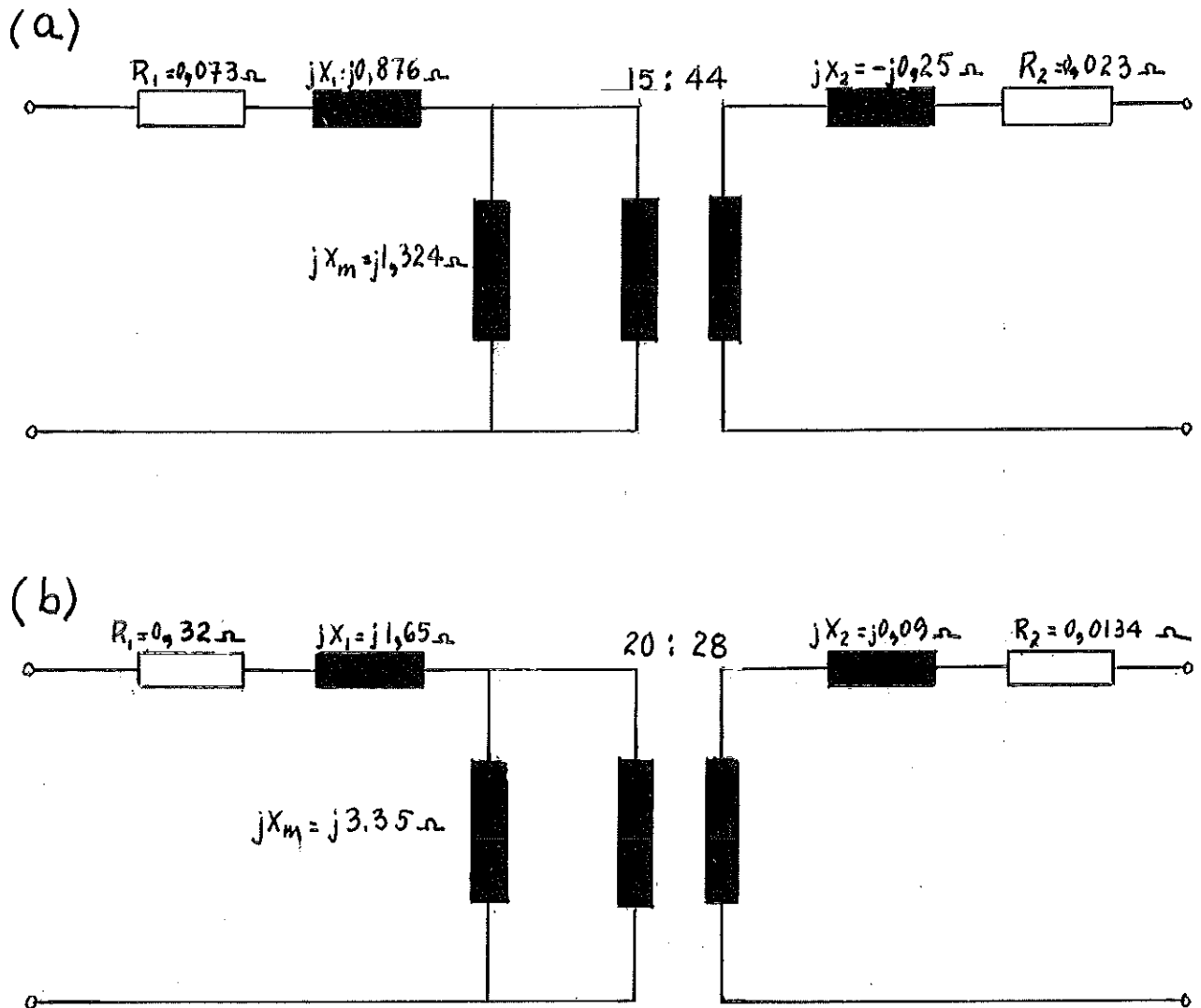

Figure 6.: a) D magnet equivalent circuit
(backleg winding and main winding)
b) F magnet equivalent circuit
(backleg winding and main winding)

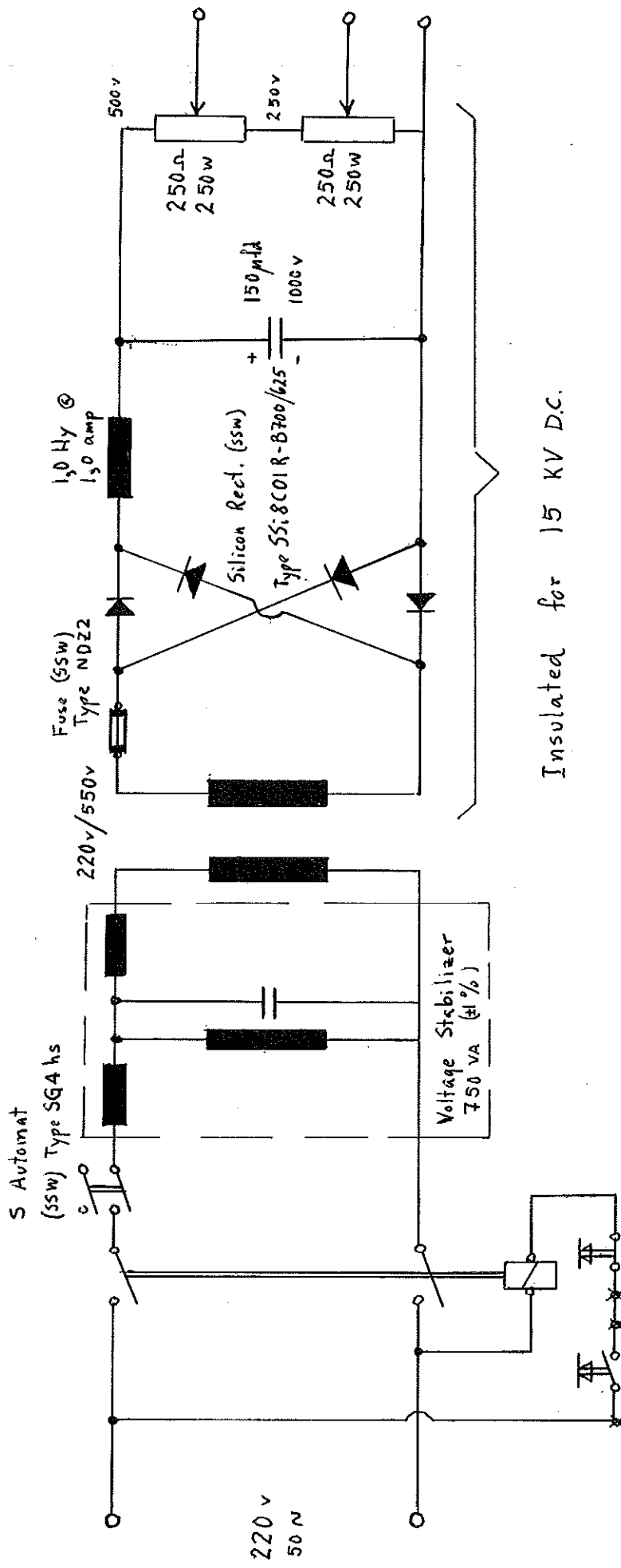

Figure 7.: Grid Bias Power Supply.

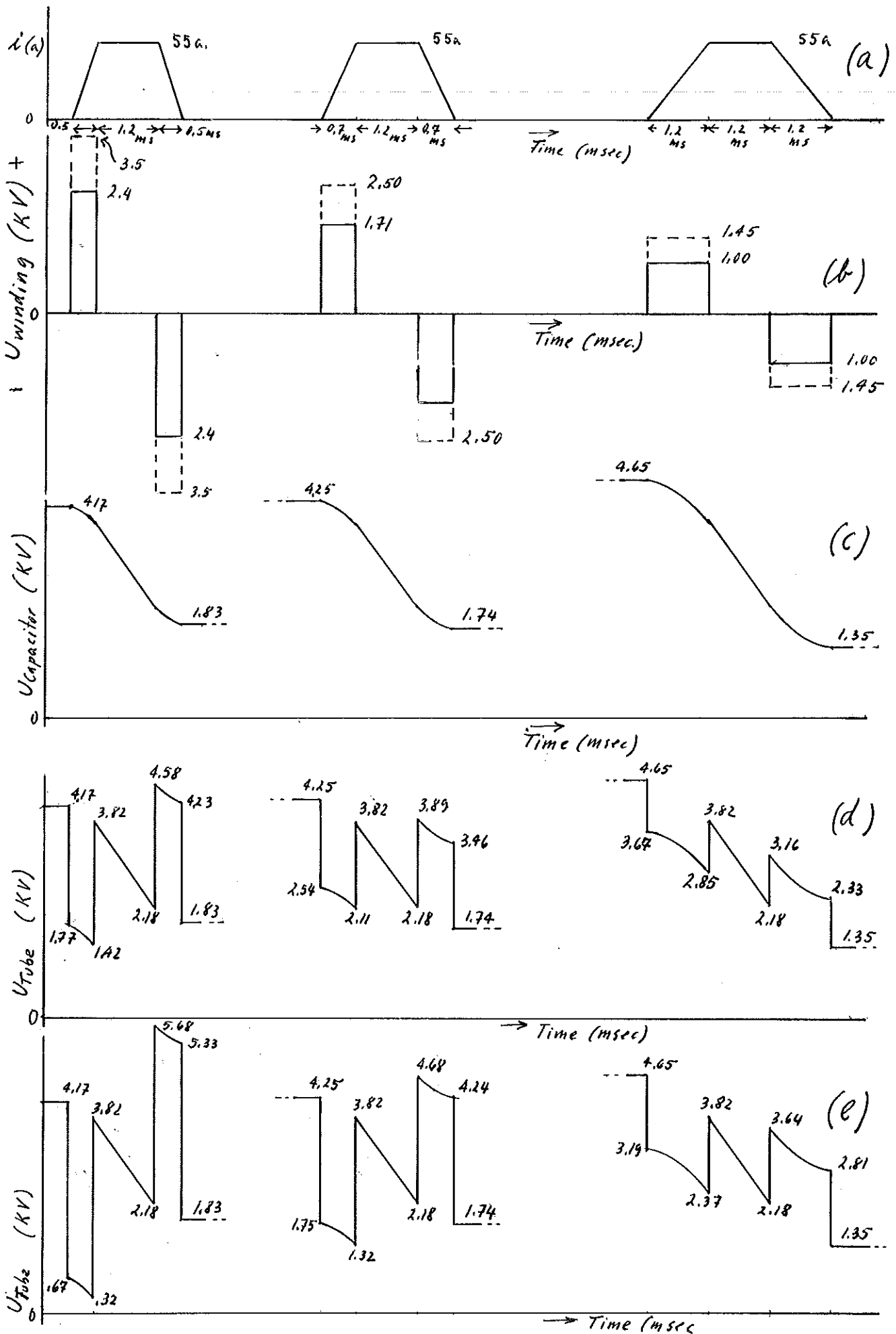

Fig 8.: E-Pulsar waveshapes a) Current b) Backleg winding voltage, dotted line; Airgap winding voltage, solid line c) Capacitor C voltage d) Tube voltage for airgap winding e) Tube voltage for backleg winding.

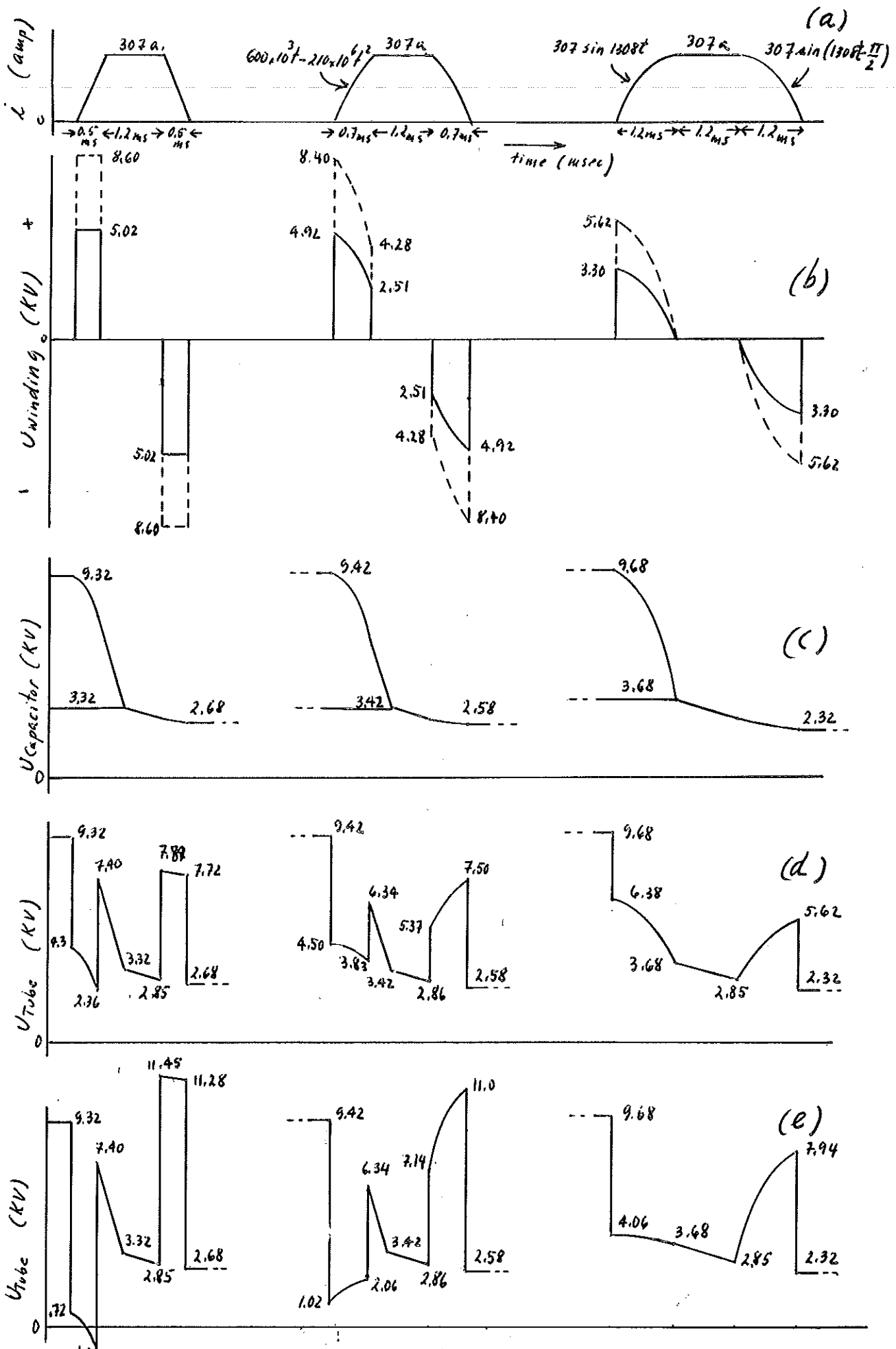

Fig. 9.: D Pulser waveshapes a) Current b) Backleg winding Voltage, dotted line; Airgap winding voltage, solid line c) Capacitor C_1 and C_2 voltages d) Tube voltage with airgap winding e) Tube voltage with backleg winding.