

DEUTSCHES ELEKTRONEN-SYNCHROTRON **DESY**

DESY 80/109  
November 1980

TRIGGER AND DECISION PROCESSORS

by

G. Franke

NOTKESTRASSE 85 · 2 HAMBURG 52

**DESY behält sich alle Rechte für den Fall der Schutzrechtserteilung und für die wirtschaftliche Verwertung der in diesem Bericht enthaltenen Informationen vor.**

**DESY reserves all rights for commercial use of information included in this report, especially in case of apply for or grant of patents.**

**To be sure that your preprints are promptly included in the  
HIGH ENERGY PHYSICS INDEX ,  
send them to the following address ( if possible by air mail ) :**

**DESY  
Bibliothek  
Notkestrasse 85  
2 Hamburg 52  
Germany**

## 1. Introduction

Rates of some  $10^5$  Hz in high energy nuclear physics experiments force the physicists to build triggering devices, which reduce the rates by several orders of magnitude, such that event data acquisition and analysis, which are strongly limited to a few Hz, become feasible.

For many experiments such a reduction is meaningful, because the rate of events with some relevance to physics is lower by many orders of magnitude.

Integrated electric circuits play an important role in many trigger and decision processors. Therefore cycle times of the ICs are a limiting factor in speed on all levels of the selection.

Complexity and time consumption of the processes increase with the accuracy to be achieved. So the approach to physics obviously has to proceed in steps.

## 2. Decision Levels and Triggering Devices

These steps can be characterized by three levels for many experiments (Fig. 1):

- a) Pretriggers are often set up by simple coincidence circuits. They are important, if parts of the electronics like latches, ADCs or TDCs have to be started or strobed.
  - b) Master triggers are more complex but fast logic devices. They are often realized in coincidence matrices or special purpose processors. Rates and timing arguments can result in solutions, for which this step is divided into sublevels.
  - c) Online filters provided by microprocessors or mini-computers reduce the rates.
- Exceptions from this scheme are found in many experiments. Often no online filtering is necessary. Triggering can be done in one step even in complex experimental set-ups as the CELLO-Collaboration has shown [1]. The structure of the decision process also depends upon the triggering devices: wire chambers, shower counters, scintillation counters and hodoscopes, Čerenkov counters, beam supplied timing signals. Most of them are fast and the

## TRIGGER AND DECISION PROCESSORS

G. Franke

Deutsches Elektronen-Synchrotron DESY, Notkestraße 85, D 2000 Hamburg 52

### Abstract:

In recent years there have been many attempts in high energy physics to make trigger and decision processes faster and more sophisticated. This became necessary due to a permanent increase of the number of sensitive detector elements in wire chambers and calorimeters, and in fact it was possible because of the fast developments in integrated circuits technique.

In this paper the present situation will be reviewed. The discussion will be mainly focussed upon event filtering by pure software methods and rather hardware related - microprogrammable processors as well as random access memory triggers.

---

Talk given at the EPS-Conference on Computing in High Energy and Nuclear Physics, Bologna 1980

corresponding signals are delayed typically by some 10 nsec relative to the interaction time. But wire chambers are slow due to drift velocities of about 1 cm/μsec. The JADE jet-chamber [2] has a maximum response time of 2 μsec, for the time projection chamber [3] it will be even longer. So it is necessary to add extra triggering devices like scintillation hodoscopes or fast wire chambers. Another reason for breaking up the master trigger into sublevels can be given by a slow triggering device. The PLUTO experiment uses a sequential logic [4] as main part of the wire chamber trigger with a maximum processing time of 50 μsec. This was acceptable only after the rates had been reduced by means of a fast random access memory coded master trigger.

### 3. Filtering Methods and Decision Processors

A variety of particle and event properties are utilized in triggering and filtering processes. The types, geometry and accuracy of the chambers and counters used in a specific experimental set-up are important. Timing, topological and kinematical criteria are the main features of particles and events used for decisions about the physical relevance of an event.

Proceeding from these criteria certain variables are defined which can be accumulated in spectra or distributions, and event filtering is done by applying cuts to these distributions in which genuine events may show up as peaks or be bounded by thresholds.

Some of the quantities which event filtering is based upon are:

- a) time correlations between counters and the interaction time in a bunched accelerator
- b) time of flight
- c) correlations of drift times caused by the same particle in adjacent drift chambers
- d) multiplicities of the coordinates in a chamber or a hodoscope
- e) track multiplicities in wire chambers
- f) cluster multiplicities in shower counter arrays
- g) number of points on a track (redundancy)

- h) track momentum or correlated quantities like curvature, sagitta etc.
- i) distances of nearest approach to a target or interaction point
- j) angular correlations
- k) invariant masses
- l) energy sums.

### 3.1 Processor Elements

It is not easy to say in general how a processor doing the just defined jobs has to look like. There are many solutions, most of them are special. But it is possible to state the most important processor components in a relatively short list:

- a) Memories or logical arrays are utilized in almost all of them. In recent years, processors in which the memory is the essential part came into common use.
- b) Arithmetic logical units or moduls carrying out important and often used calculations are part of many processors.
- c) Finally all components have to communicate via buses or channels.

Due to the steadily growing importance of memories, I go into some details:

- a) a random access memory (RAM) with N address lines has  $2^N$  gates to address the RAM cells storing one bit information each. Output is a logical function of the address. By addressing enough RAMs in parallel one can get any function of the input in less than 50 nsec (look-up table). The RAMs can be reloaded whenever wanted. Coding of the 'intelligence' is done on a normal computer. No programming, code assembling or interpreting is done in the RAM itself. All software work is remote. A RAM matrix is used to store (logical) correlation functions. Un-coded data, e.g. coordinate pairs, are used as input.
- b) In programmable logical arrays (PLA, FPLA) the disjunctive normal form of Boolean expressions is utilized. Inverters and gates are connected corresponding to the logical expressions. No reprogramming is possible.
- c) Content addressable memories (CAM) are used to parallelize a search procedure. The input is compared (in parallel) to all memory words. If input and content match, then the address is given out. In the full association mode all input bits are compared to the content, both have to be equal. In the masked

association only predefined bits are compared, which have to be equal for input and content.

### 3.2 Track Finding Processors

Most important criteria for triggering and event selection are the geometrical and kinematical properties of tracks. Therefore many attempts have been made to install efficient and fast processors (both hard- and software) which are able to cope with this problem.

The method of track finding implemented into a dedicated processor depends upon the specific problems and features of the experiment like track multiplicity and density, background properties and the type and geometry of the chambers or hodoscopes.

#### 3.2.1 Road Methods

Roads are defined by point pairs or triples (pivot points), which have to be systematically selected from the measured coordinates, and a track model, e.g. straight line, circle, spline curve, interpolating between these points (Fig.2). Inside the road further coordinates are searched. A track (candidate) is found, if a minimum number of points (or more) are found inside the road. This minimum number depends upon the number of chambers, their efficiency and geometry. The road width depends upon the chamber resolution and geometrical adjustment and upon multiple Coulomb scattering expected in the set-up.

The TASSO Collaboration [5] at PETRA uses the microprocessor MONICA [6] to find tracks in the inner detector drift chambers. IDC data are read from 9 chambers. The azimuthal coordinates are calculated and stored in 9 CAMs, one for each chamber (Fig.3). Roads are defined by two drift chamber points and the interaction point (Fig. 4). The trigonometric-geometrical expressions needed for the road calculations are stored in PROMs (Fig. 3). Searching in the road is done by addressing the CAMs with the road coordinates. So there is no need for the ALU, which is an ECL slice processor, to carry out operations on a level higher than adding and subtracting. MONICA needs about 1 msec for the reconstruction of a 5-prong event, and is able to reduce the rate of noncollinear 2-prong events by more than one order of magnitude to about 1 Hz [7].

The CERN-NA3 experiment [8] uses the straight line finder MORPION [9] for a set-up of MWPCs. It applies a road method to up to eight chambers. The search for coordinates in the roads is done in parallel processors, one for each chamber. Once the first and last point  $f$  and  $l$  are selected, the road points  $p$  in the other chambers can be calculated very fast

$$p = f + C_{flp} \cdot (l-f),$$

because the geometrical interpolation weights  $C_{flp}$  are stored in tables. The whole process is about 10 times faster than on a CDC 7600. The PDP 11-45 experimental host computer is able to make a 3-dim. event reconstruction, and to calculate the dimuon mass for specific kind of events.

The PLUTO-Collaboration at PETRA [10] uses an offline filter programme mainly based on a road method. It takes the data from 13 cylindrical wire chambers and 7 shower counters (Fig.5). The roads are initiated in 5 pairs of pivot wire chambers (Fig. 6). The track length requirement is diminished proceeding from one pair to the next. An event is only accepted, if two tracks (with  $\geq 5$  points each) or one long track ( $\geq 8$  points) are found or a predefined amount of energy is seen in the shower counters. The amount of events triggered by the inner detector is thus reduced by a factor of 15 using 30 msec/event on an IBM 370/168. The online implementation into a microprocessor 168/E [11] is planned.

#### 3.2.2 Mask Methods

A similar approach to track finding only uses the track model for initialization but not the measured points in an event. The track parameters may be assumed to define a space. The acceptance cuts applied in an experiment set limits to the interesting part of the track parameter space, thus defining an acceptance volume. This volume is binned, e.g.  $\kappa \pm \Delta \kappa$ ,  $\phi \pm \Delta \phi$ . Each bin defines one mask. The track parameter space is 3-dimensional for curved tracks in one projection, but the dimension is in most cases reduced by one constraint (interaction point, target) see Fig. 7.

The TASSO Collaboration takes the data from 6 cylindrical drift chambers and puts them into curvature masks [12] (15 per each of 72  $\phi$ -directions). The maximum curvature corresponds to a momentum cut of 180 MeV/c. A 5 out of 6 majority logic is coded in FPLAs for each mask. All masks work in parallel in about 800 nsec so that a reset signal is possible 1.4  $\mu$ sec after the interaction,

This is before the next PETRA bunch crossing (1.9 usec). Double recognition of tracks is a problem, and it is not easy to get rid of it, because of the unchangeable FPLA coding.

The CELLO Collaboration [1] feeds the data from 7 cylindrical wire chambers into curved masks in the r-φ-projection and into straight masks in the r-z-projection. The majority logic is coded in RAMs for all masks in parallel. The flexibility due to the reprogrammability of the RAMs is a great advantage. Doubly counted tracks can be recognized in the experimental host computer and the trigger rate can thus further be reduced.

The PLUTO Collaboration uses a sequential logic [4] as third level trigger. The data from two sets of 4 cylindrical chambers are OR-gated in 30 sectors and stored in 120 bit shift registers. The data are rotated and compared with mask patterns at an observation station in a '3 out of 4' majority logic. A full rotation needs 50 usec.

The SLAC/LBL MARK II Collaboration [13] uses shift registers to store and rotate the cylindrical drift chamber and liquid argon shower counter data [14]. RAMs contain a track classification logic. This trigger is slow but less expensive than parallel processors.

The JADE Collaboration [2] at PETRA has a second level trigger for the cylindrical jet chamber. In this trigger the high redundancy on charged tracks is strongly utilized. The answers from the cell triggers on about a dozen points are put into an FPLA coded mask logic. The masks are quite coarse, but this is no disadvantage due to the high number of points used.

### 3.2.3 Track Multiplicities

The properties of the tracks found during the process of track finding are used to come to a final decision. Counting them and asking for a minimum number is the simplest method and often sufficient. In the e<sup>+</sup>e<sup>-</sup>-storage ring experiments it is customary. Refined multiplicity definitions have to be applied, if the tracks have a quality marker (e.g. low and high redundancy tracks). This is utilized in the PLUTO and MARK II experiments.

### 3.3 Momentum and Mass Triggers

In the just discussed mask processors the implied momentum cuts are kept as low as possible. But there are applications for instance in high transverse momentum experiments, where the momentum has to be known accurately for tight cuts.

In the Axial Field Spectrometer [15] (R 807) at the ISR, the transverse momentum of one track is calculated online. Hardware-preselected drift chamber data are read by a microprocessor of the ESOP type [18] which calculates the sagitta of a track from 4 point-quadruples ('master points') in some 10 usec [16].

In the charmed particles production experiment (CERN - NA 11) at the SPS two ESOPs are used as second level trigger processors [19]. They try to find and identify a high momentum electron by calculating its momentum and energy. The false triggers are recognized in 200 - 300 usec.

The European Hybrid Spectrometer [20] will use three ESOPs for both, secondary triggering and data compression.

The examples show that ESOP is quite a flexible processor. High speed, fast DMA read-out, parallelism and special instructions, e.g. fast loop control and comparison, make ESOP one of the most interesting and flexible tools for second level triggering and online filtering. The possibility of increasing the lifetime of the detector and/or sensitivity to certain processes [21] is strongly utilized in the CERN/NA 11 experiment.

The CERN μ-pair experiment NA3 at the SPS measures track momenta by means of specially designed cathode read-out chambers and a fast processor [22]. I mention only one aspect of the system, namely that the inverse momentum projections are proportional to differences of cathode-strip numbers of two chambers. The differences are used to address ECL-RAMs, which contain the P<sub>t</sub>-cut coding.

A similar approach was made in a μ-pair experiment at FNAL. The mass calculation could be performed without doing multiplication by using a logarithmically binned hodoscope. Matrices transform the coordinate correlations into momentum and angle expressions, which are added in a fast ECL processor [23]. Basically the expression  $\log(M_{\mu\mu}^2/2) = \log(p_1) + \log(p_2) + \log(1 - \cos \theta)$  is evaluated.

The FNAL experiment # 400 uses an ECL microprocessor [24] to reconstruct  $\mu$ -pair events from two drift chambers. Cuts for transverse momenta and the invariant pair mass are calculated. The processor can evaluate expressions of the type  $A \cdot x + B \cdot y$  in one instruction. The multiplications are done parallel. The system provides a second level trigger in 2  $\mu$ sec.

The CERN-ISR-Experiment R 110 triggers on high mass  $e^+e^-$  - pairs [17]. The hardware trigger accepts two energetic clusters in the shower counter / lead glass arrays. The online computer calculates the mass and applies a cut. An improvement will be realized by searching for cluster correlated tracks in the inner detector drift chambers by means of a microprocessor and refine the mass calculation and cut [25].

For the Multi-Particle Spectrometer at BNL a three-dimensional RAM-matrix [26] was developed offering a variety of applications. Target pointing of curved tracks is possible, track recognition and momentum definition from three chambers.

#### 3.4 Angular Triggers

In some experiments angles are utilized by the triggers.

The European Muon Collaboration uses fast programmable coincidence matrices [27] to trigger on hodoscope coordinate correlations [17]. Angular cuts near the beam, target pointing in two projections and a momentum cut are coded in the matrices.

The CERN/PS experiment S 157 measuring the total  $\pi^+p$  - crosssection uses an intelligent CAMAC - controller / branch driver [28] to calculate the interaction angle for simple events.

#### 3.5 Calorimetric Triggers

Shower counters are - besides wire chambers and hodoscopes - the other important field of detectors utilized for triggering. Requiring a certain amount of shower energy in a trigger scheme can decrease the trigger rate tremendously. Calorimetric triggers are often simple and in many cases set up by standard modules. But there are several recent developments to more sophisticated triggers or filters based

on shower counters. Most important in this context are cluster finding procedures. As a consequence there are many features reminiscent of track chambers like multiplicity counting and topological selections.

The Axial Field Spectrometer [15] (CERN/ R 807) at the ISR attempts a full azimuthal coverage with uranium-scintillation sandwiches. The signals will be summed to azimuthal bins. Electromagnetic sums (from the first six rad. lengths), single particle sums and broader jet sums are provided. Multiplicity counting is done at different discrimination levels. The corresponding signals are collected together with other signals on a 50 lines bus. Via 250 ECL memory chips up to 50 triggers are performed in about 200 nsec.

The JADE Collaboration has about 3000 lead glass Čerenkov counters as part of the inner detector. They form a barrel with two endcaps. A cluster procedure running online in the experimental host computer is able to identify 90% of the 1-photon-events with about 10% background by counting the clusters and demanding at least seven [29].

For the  $p\bar{p}$  - Collider experiment UA1 many decision levels are provided. One interesting detail is the extensive application of RAMs [17]. Transverse momentum processors are foreseen to convert digitized calorimeter stack signals into transverse components. For the muon chambers surrounding the whole detector in two double layers directional triggers towards the interaction region will be coded in RAMs.

The MARK-J [30] experiment at PETRA applies a multiplicity trigger to the inner detector shower counters. A total energy cut is made for multihadronic events, which can be improved online by energy calculations in a microprocessor (BIRA MBD). Track elements in the drift chambers are searched by the MBD and are counted for the muon and hadron triggers.

#### 3.6. Master Triggers

In large experiments with many collaborators the trigger can constitute a major organizing problem. Each subgroup has built part of the experimental set-up including also part of the trigger, which yields a larger number of signals. But for the final trigger exactly one 'YES' or one 'NO' is necessary. This

requires a device which collects all this useful information and merges it.

The PLUTO Collaboration solved this problem at PETRA by a staggered system of RAMs [31]. Triggering devices are the inner detector wire chambers, three inner detector shower counters and four forward detector shower counters. Each subsystem (Fig. 5) makes its own pretriggers:

- a) 5 wire chamber pretriggers on single track elements
- b) 5 wire chamber pretriggers on track element pairs
- c) 5 barrel shower counter conditions  
(low, medium, high thresholds, topol. and QED triggers)
- d) 5 endcap shower counter conditions (same as barrel)
- e) 1 low and 1 high threshold condition from each forward shower counter.

These signals go into three RAM units (Fig. 8), the pretrigger encoders, with ten input lines each and three output lines (3 x 1024 Gates). The RAMs are programmed such that the output is a quality function of the input. A low inner detector shower counter signal results in a '1', a high signal in a '7'. The output signals of all encoders are put into the fast master trigger RAM, which reduces the pretrigger rate by three orders of magnitude. The fast master trigger output signals together with the RAM-encoded sequential logic signals are put into the slow master trigger, which makes the final decision and reduces the rate by another two orders of magnitude. The RAMs are programmed by a simple editor and are loaded via CAMAC.

### 3.7 Closing Remarks

For fast triggering also in the future individual solutions will be necessary due to the large number of special parameters and conditions given by experiment and accelerator. The applications of memories used as look-up tables will probably be extended.

Event filtering will more and more be done online. Several microprocessors were built (ESOP [18], MICE [32], 168/E [11]) or are under construction (FAMP [33]), which are so flexible that they can be useful for many experiments. Highly in-

tegrated microprocessors, being almost as fast as the homemade bit slice processors are now, could open a way to make fast online processing to a standard application in a few years.

I wish to thank many physicists from CERN and DESY who supplied me with information about the topic discussed. I gratefully acknowledge Professor E. Lohrmann and Drs. L. Criegee and H.J. Stuckenberg for stimulating discussions.



R E F E R E N C E S

- [1] M.J. Schachter-Radig, CELLO - A new PETRA Detector, Int. Conf. Exp. LEP, Uppsala (1980)
- H.J. Behrend, The Trigger Decision Processor for the CELLO-Experiment at PETRA (talk given at this conference)
- [2] H. Drumm et al., Experience with the JADE Jet-Chamber at PETRA, DESY-Report 80/38 (1980)
- H. Krebbiel, The JADE Trigger System (talk given at this conference)
- [3] B. Yu. Baldin et al., Nucl. Instr. Meth. 140 (1977), 409
- [4] E. Iarocci and P. Maloschek, DESY Report 72/13 (1972)
- [5] H. Boerner et al., The Large Cylindrical Drift Chamber of TASSO, Wire Chamber Conf., Vienna (1980) and DESY Report 80/27 (1980)
- [6] P. Schildt, Entwicklung eines mikroprogrammierbaren Rechners zur on-line Rekonstruktion von Spuren für den Detektor TASSO am Speicherring PETRA, Diplomarbeit Univ. Hamburg (1979)
- P. Schildt, H.-J. Stuckenberg, N. Wermes, DESY Report 80/11 (1980)
- [7] N. Wermes, private communication
- [8] J. Badier et al., A Large Acceptance Spectrometer to study High-Mass Muon Pairs (to be publ. in Nucl. Instr. Meth.)
- [9] M. Mur, MORPION: A Fast Hardware Processor for Straight Line Finding in MMPC, Wire Chamber Conf., Vienna (1980)
- [10] L. Criegee, G. Knies,  $e^+e^-$  - Physics with the PLUTO Detector, Phys. Reports, to be published
- [11] P.F. Kunz, Nucl. Instr. Meth. 135 (1976), 435
- P.F. Kunz et al., SLAC-PUB-2198 (1978)
- P.F. Kunz et al., SLAC-PUB-2418 (1979)
- [12] H. Lynch, private communication
- [13] W. Davies - White et al., Nucl. Instr. Meth. 160 (1979), 227
- [14] H. Braffman et al., IEEE Trans. Nucl. Sci. NS-25, No. 1 (1978), 692

- [15] H.J. Hilke, Performance of the AFS-Vertex Detector at the CERN ISR Int. Conf. Exp. LEP, Uppsala (1980)
- H. Gordon et al., The AFS Trigger System at the CERN ISR, Int. Conf. Exp. LEP, Uppsala (1980)
- [16] B. Heck, private communication
- [17] H. Verweij (editor), CERN EP-Electronics Note 80-04 (1980)
- [18] T. Lingjaerde, CERN Internal Report DD/75/17 (1975)
- [19] G. Lütjens, private communication
- C. Danereil et al., Use of the ESOP fast processor in the trigger logic of the CERN experiment NA 11 (talk given at this conference)
- [20] D. Jacobs, Applications of ESOP, a fast microprogrammable processor, in high energy physics experiments at CERN (talk given at this conference)
- [21] M. Turala, Applications of Wire Chambers for Triggering Purposes, Wire Chamber Conf., Vienna (1980) and CERN Internal Report EP 80/60 (1980)
- [22] J. Boucrot et al., A Trigger System using Cathode Read-out Chambers and a Coincidence Matrix, LAL 79/33 Preprint, Orsay 1979 and to be publ. in Nucl. Instr. Meth.
- [23] G.E. Hogan, Nucl. Instr. Meth. 165 (1979), 7
- [24] T.F. Droege, I. Gaines, K.J. Turner, IEEE Trans. Nucl. Sci. NS-25, No. 1 (1978), 698
- [25] W. Phinney, private communication
- [26] E.D. Platner et al., Nucl. Instr. Meth. 140 (1977), 549
- [27] W. Flauger, Nucl. Instr. Meth. 165 (1979), 113
- [28] E. Barrelet, R. Marbot, P. Matricon, CAMAC BOOSTER, A Versatile Micro-computer for High Rate CAMAC Data Acquisition, Preprint LPNHE/X/79, Ecole Polytechnique, Palaiseau (1979)
- [29] P. Dittmann, private communication
- [30] D.P. Barber et al., Phys. Reports 63 (1980), 337

- [31] K.H. Pape, Entwicklung und Untersuchung des RAM-Triggers für den Detektor PLUTO, Diplomarbeit Univ. Hamburg (1979)
- [32] C. Halatsis et al., 7<sup>th</sup> International Symposium on Computer Architecture, La Baule, France (1980)
- [33] M. Carels et al., FAMP System (talk given at this conference)

FIGURE CAPTIONS

- Fig. 1 Trigger and decision steps and rates
- Fig. 2 Road method
- Fig. 3 Block diagram for the microprocessor MONICA
- Fig. 4 Road method applied by the microprocessor MONICA
- Fig. 5 PLUTO detector at PETRA. Triggering devices are:  
MMPC: cylindrical wire chambers  
BA: barrel shower counter  
EC: endcap shower counter  
LAT: large angle tagger  
SAT: small angle tagger
- Fig. 6 Road method applied for the PLUTO experiment
- Fig. 7 Mask method
- Fig. 8 PLUTO RAM trigger

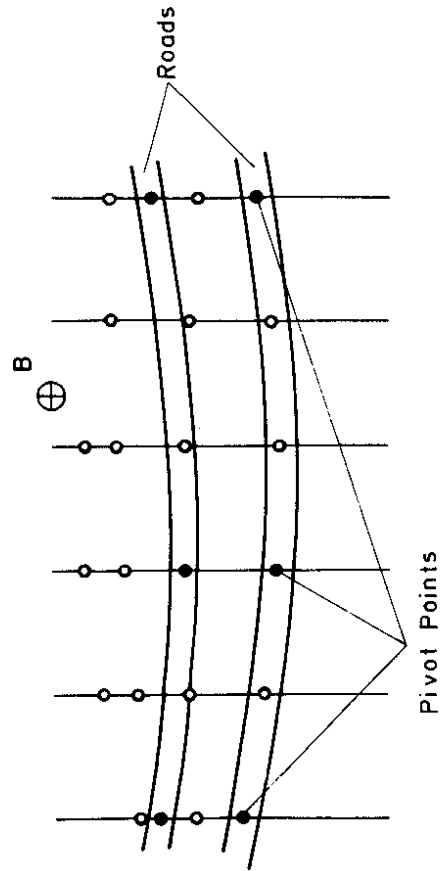

Fig. 2

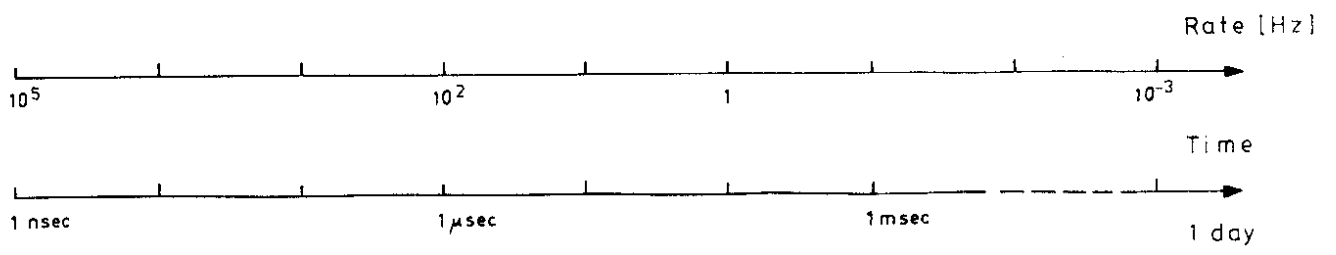
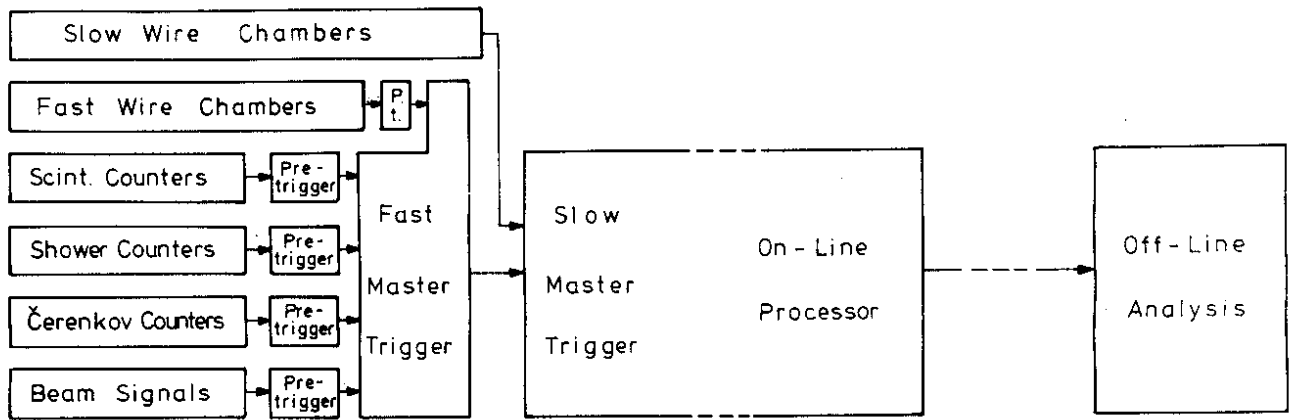

Fig. 1

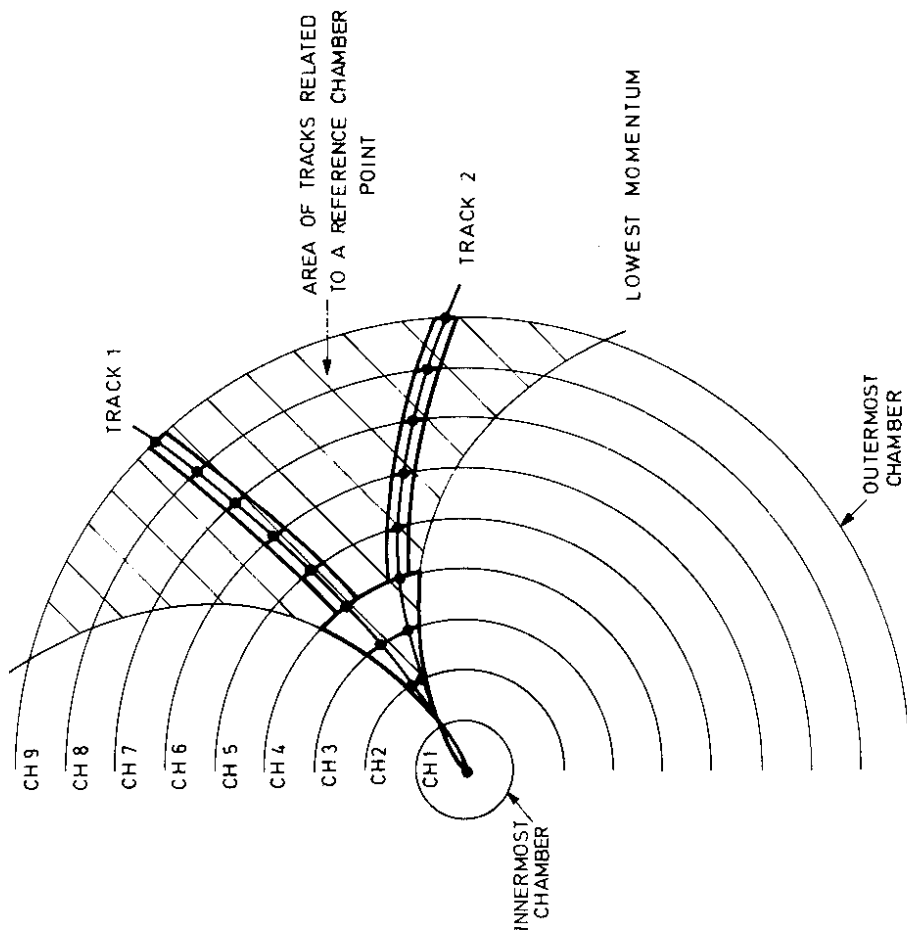
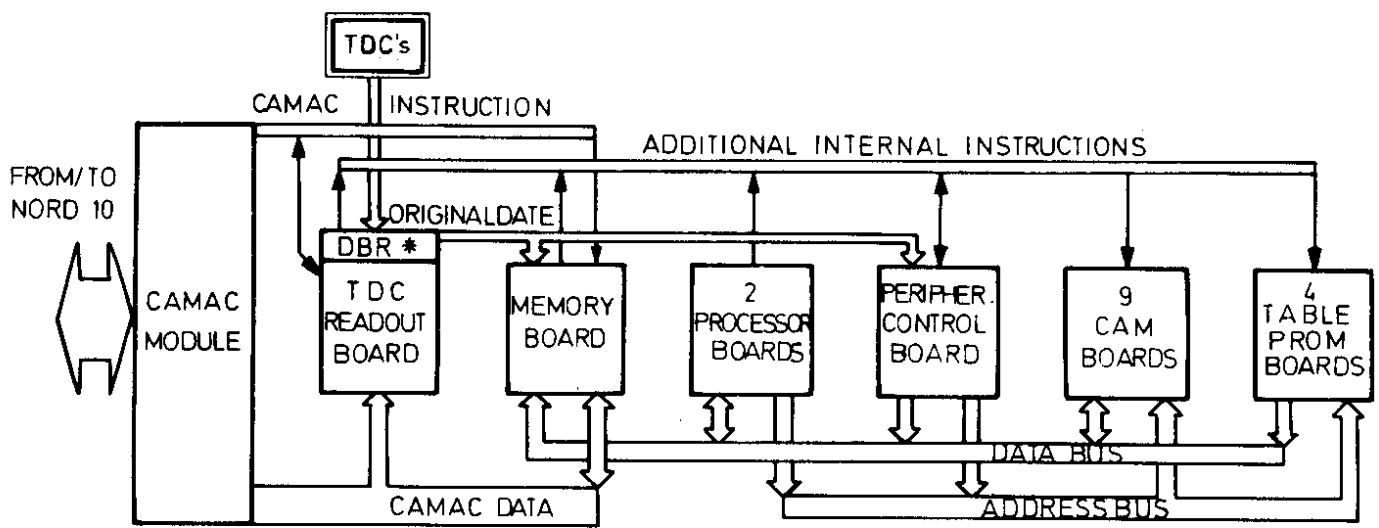

Fig. 4



\* DBR = DATA BUFFER REGISTER ON THE TDC READOUT BOARD

Fig. 3

# PLUTO

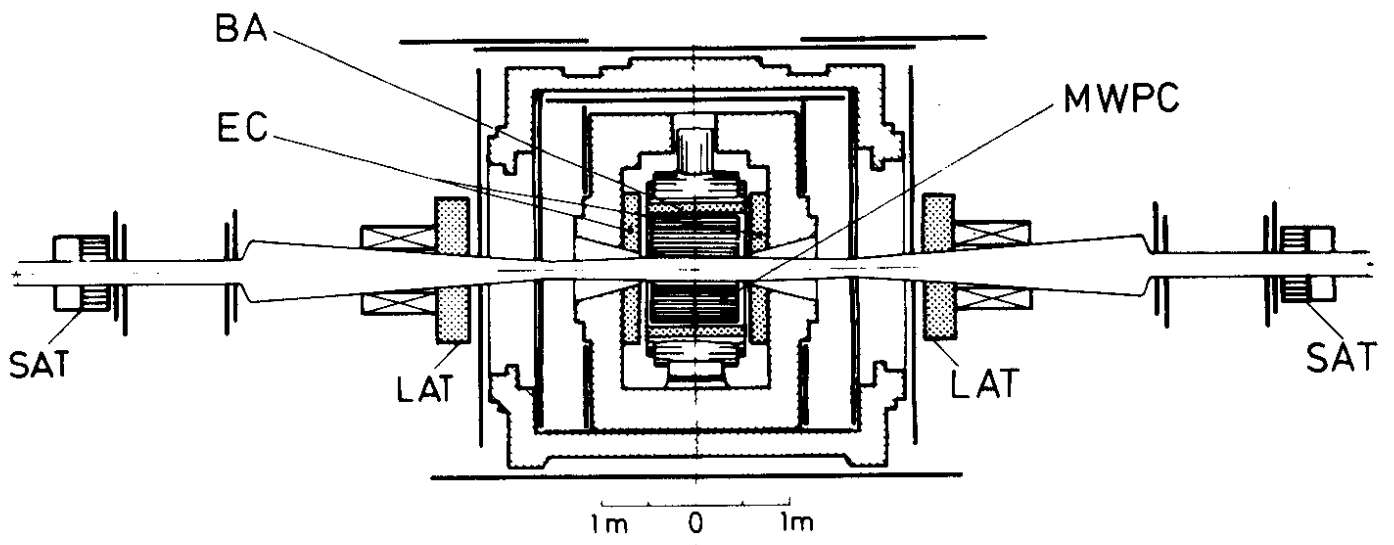

Fig. 5

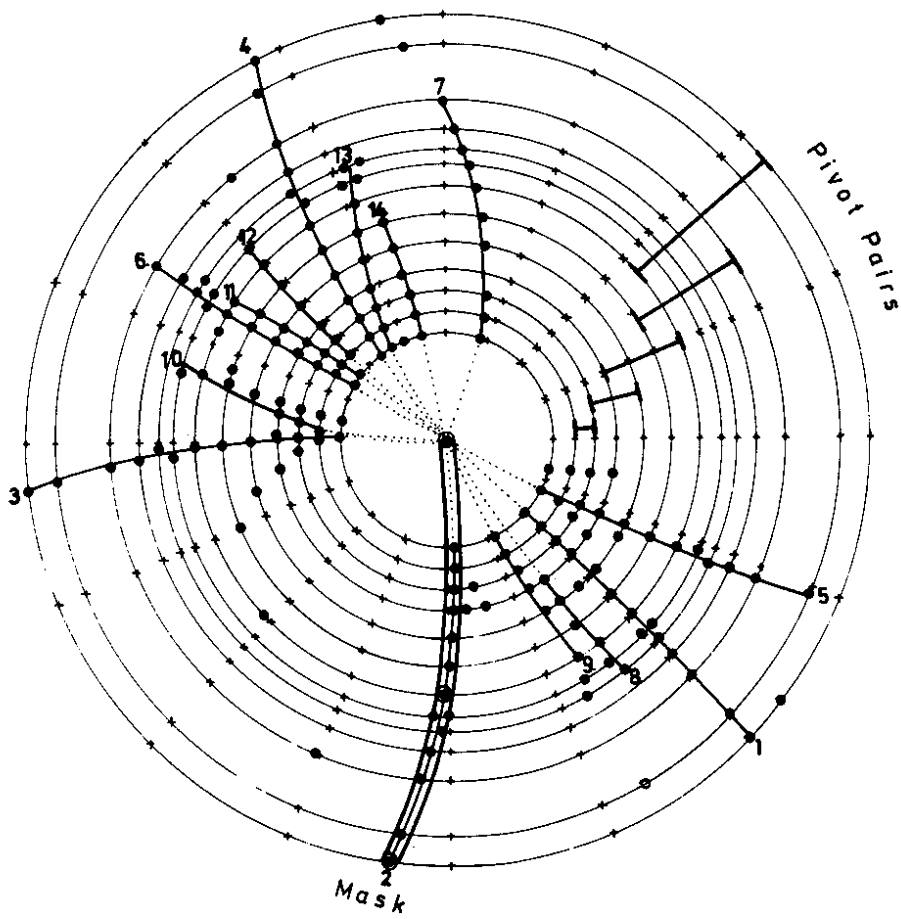

Fig. 6

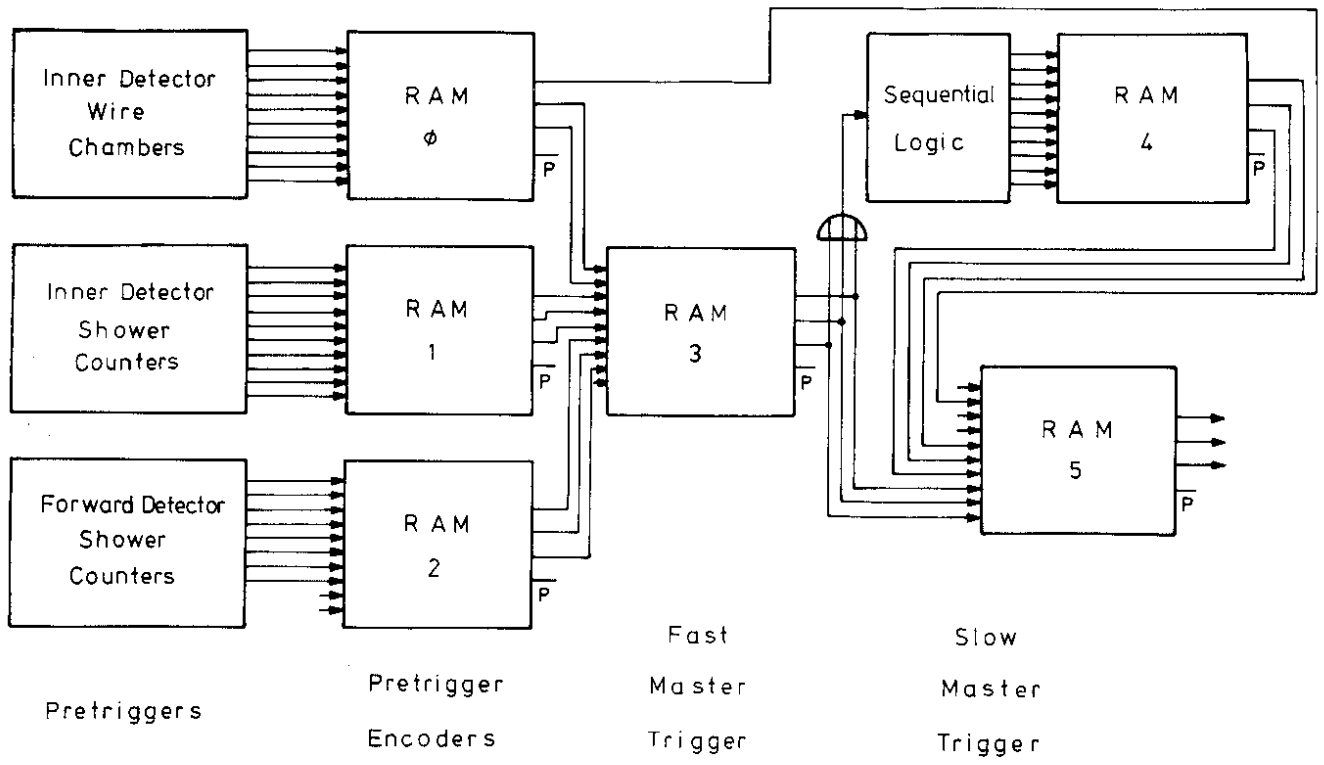

Fig. 8

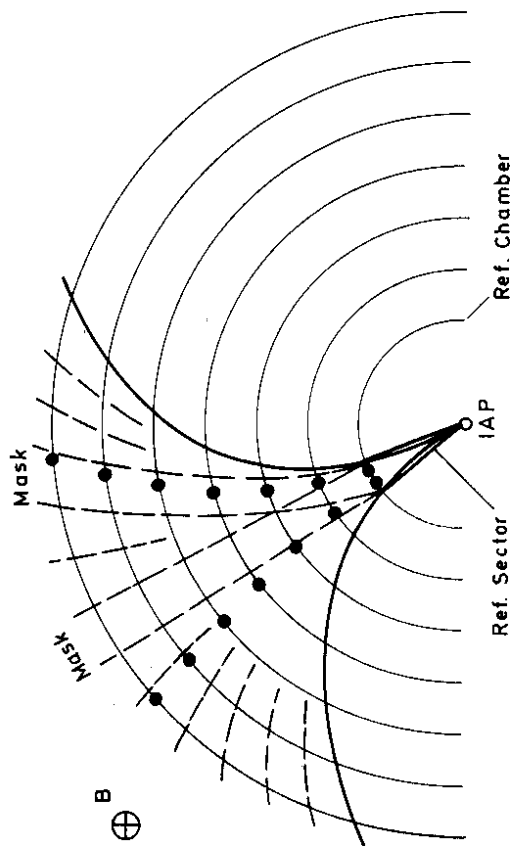

Fig. 7