

Interner Bericht  
DESY KI-71/1  
~~Dezember 1971~~

DESY-Bibliothek

14. FEB. 1972

TWO METHODS FOR CALCULATING D.C. THYRISTOR POWER SUPPLY  
REGULATOR PARAMETERS

by

M. Levy

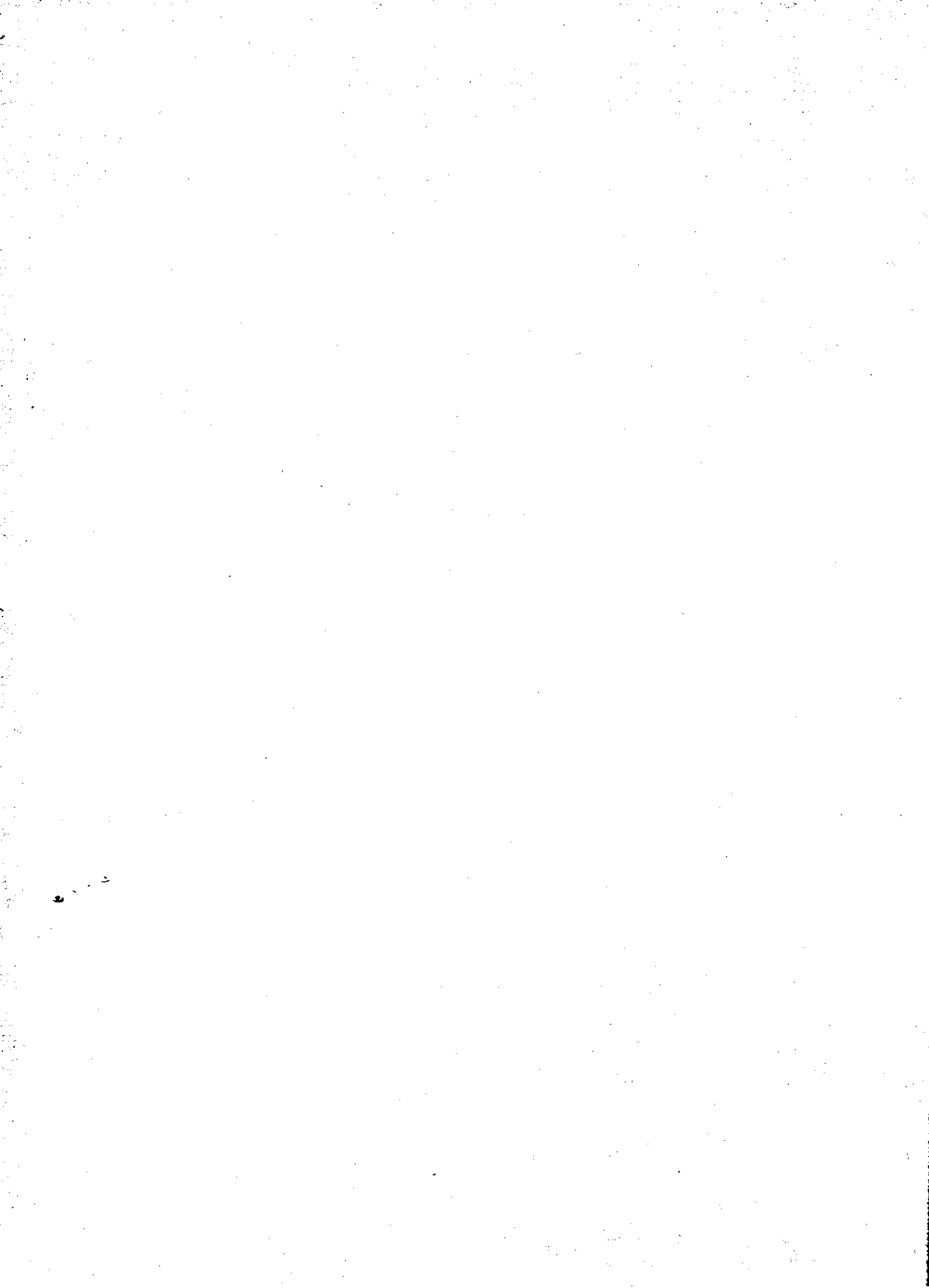

## Introduction

Two methods for approximately gaining the optimal regulator parameters for a Thyristor DC power supply are described and compared.

At DESY a PI regulator with constant parameters regulates the power supply units which feed the various kinds of beam transport magnets.

The condition that during a transient period caused by a sudden main perturbation the deviations of the regulated magnet current should be smaller than a given tolerance demands that the regulator should work with optimal values.

Since the time constant of the different magnets has a large range of variety the optimal values of the regulator must be found as a function of this value.

Our first method, the simulation of the problem on an analogue computer, is based on a theoretical approach given in [1]. The idea of sampling and holding can easily be carried through on the analogue computer with the help of a memory unit. The second method uses a digital computer with the "CSMP" oriented in-pu language. For the gate control circuit we used the same idea as given in [2].

## Simulation on an Analogue Computer

The simulation network consists of a Thyristor 3ph. bridge connected power supply, a magnet as a load and a PI regulator.

The block diagram of the control circuit is given in Fig 1. In order to reduce the complexity of the problem some simplifications are assumed:

- 1) The Thyristor rectifier system is taken as a D.C. voltage source.
- 2) Only transient periods are simulated.
- 3) The disturbing signal is small.
- 4) Commutation phenomena are neglected.
- 5) The gate control network is linear.
- 6) The magnet has constant values of R and L.

## Analogue Computer Scaling

The network on the analogue computer Telefunken Type AR 770 is given in Fig.5.

In order to obtain results the various constants must be scaled and, in addition to this, a scaling factor between real time and machine time must be defined.

### Analogue Computer Scaling

The network on the analogue computer Telefunken Type AR 770 is given in Fig.5.

In order to obtain results the various constants must be scaled and, in addition to this, a scaling factor between real time and machine time must be defined.

Due to magnitude scaling the operational amplifiers never reach the saturation conditions whereas time-scaling enables us to obtain results in a reasonable length of time although real events occur very quickly.

In our case we define the relation between  $t$ , real time, and  $\tau$ , machine time, as follows:

$$t = \beta \tau$$

$$\beta = 3 \times 10^{-2}$$

which means that a real 30 msec event is, for example, simulated on the computer in 1 sec. When using time-scaling we should remember that every element which is time dependent must be transferred to the  $\tau$  axis.

The results of our scaling on the potentiometer setting is given in Table 1.

### Digital Computer Calculations

Our second method for calculating the same problem was to use a digital computer but without eliminating the A.C.source. We, therefore, tried to solve a problem, as can be seen in the diagram in Fig. 6.

The in-put source is a three-phase A.C.voltage:

$$U_1 = A \sin \omega t$$

$$U_2 = A \sin \left( \omega t + \frac{2\pi}{3} \right)$$

$$U_3 = A \sin \left( \omega t - \frac{2\pi}{3} \right)$$

The rectifier unit of six Thyristors connedted in 3 ph. bridge connections.

The gate control circuit was computed according to the function generator seen in Fig.7. The whole system was computed with the help of the C.S.M.P. (Continuous System Modeling Programme) on the I.B.M. 360 Computer System. The text of the programme is as follows:

```
*****CONTINUOUS SYSTEM MODELING PROGRAM*****  
  
***PROBLEM INPUT STATEMENTS***  
  
MACRO UA=GSATZ(H,Z,UC,TN,UYX,UT,U)  
UD=INSW(U,H,Z)  
D=INTGRL(UC,UD)  
UX=D/TN  
UK=ABS(UX-UYX)  
UU=COMPAR(UK,UT)  
UA=UU*U  
  
ENDMAC  
INIT  
CONST H=-1.,Z=1.,OM=314.159,TN=1.E-02,X22=0.,Y22=1.  
CONST KR=100.,USOLL=1.,KT1=-0.166,KT2=0.48,UV=0.5  
PARAM TL=(0.1,0.2,0.5,0.8,1.0,2.0)  
CONST T2=2.0944,A=1.414  
CONST TR=0.045  
DYNAM  
  
S1=STEP(0.15)  
A1=A*(1.+0.05*S1)  
FI=OM*TIME  
U1=A1*SIN(FI)  
U2=A1*SIN(FI-T2)  
U3F=A1*SIN(FI+T2)  
UY1=NOT(U1)  
UY2=INSW(U2,X22,Y22)  
UY3=NOT(U3F)  
UY22=-1.*UY2  
UA1=GSATZ(H,Z,0.,TN,UY1,UT,U1)  
UA2=GSATZ(H,Z,-0.3333E-02,TN,UY22,UT,U2)  
UA3=GSATZ(H,Z,0.6666E-02,TN,UY3,UT,U3F)  
UMX=AMAX1(UA1,UA2,UA3)  
UMIN=AMIN1(UA1,UA2,UA3)  
UIN=UMX-UMIN  
UOUT=REALPL(1.,TL,UIN)  
UABW=(UOUT-USOLL)  
UKS=KR*UABW+(1./TR)*INTGRL(C.,UABW)  
UT2=LIMIT(KT1,KT2,UKS)  
UT=UV+UT2  
  
METHOD RKSF  
TIMER FINTIM=0.4,DELT=2.E-04,CUTDEL=1.E-03  
PRTPLT UOUT(UKS,UT,A1)  
END  
STOP
```

### Results

Two graphs comparing the results obtained with the help of the two methods are given in Fig.s 8 and 9. In Fig. 8 the overshoots are given as a function of  $T_L$  (time constant of magnet) for several PI parameters. In Fig. 9 for  $T_L = 0.1$  sec. the parameters were changed in such a way that the overshoot was a minimum. From the results it can be seen that the critical setting of the regulator is for the smallest value of  $T_L$ . With such a setting the overshoot for higher  $T_L$  will be reduced although dampened oscillations will occur during transient periods.

### Acknowledgement

I would like to thank Fr1. Borchardt for her advice and help during all stages of this work; my thanks are also extended to Herr Bothe and Herr Narciss for fruitful discussions.

### References

1. F.Depping; CERN/MPS - ED 71-1
2. P.Zajicek; Interner Bericht, DESY K -70/2
3. H.Narciss; Interner Bericht, DESY K -70/1

Table I

Param. value	Pot. no.	Kind of Pot.	Time constant of magnet					Remarks
			Value of Pot.					
			0.1	0.2	0.5	1.0	2.0	
<u>U Ref. scale</u>	16	Servo	0.5000					U Ref. 1.0
K 2	3	Hand	variable					
K 1	4	Hand	"					
K 3	83	Hand	"					
U/α con- verter	60	Servo	0.6666					
α <sub>o</sub>	66	"	0.3333					
Level limiter	13	Hand	0.0030					
Comparator level	62	Servo	0.500					
Distortion function	10	"	0.050					
$\frac{\beta}{T_L} \times$ $\left(\frac{U_{dc}}{\text{scale}}\right)$	11	"	0.232	0.116	0.046	0.023	0.016	
$\frac{\beta}{T_L}$	12	"	0.300	0.150	0.06	0.03	0.015	



## Figure Captions

- Fig.1 Block diagram for the control circuit.
- Fig.2 Practical PI regulator
- Fig.3 Simulation of a PI regulator on an analogue computer.
- Fig.4 Switching diagram for the memory unit.  
a) Saw Tooth Generator switching circuit.  
b) Memory unit switching circuit.  
c) S.T.G. integrator.  
d) Memory integrator unit.  
e) Pulse diagram for comparator switch.  
f) Pulse diagram for the memory unit.
- Fig.5 Simulation network.
- Fig.6 Electrical system for digital computations.
- Fig.7 Gate control function generator.
- Fig.8 Overshoot as a function of  $T_L$ .
- Fig.9 Overshoot as a function of PI parameters for  $T_L = \text{constant}$ .

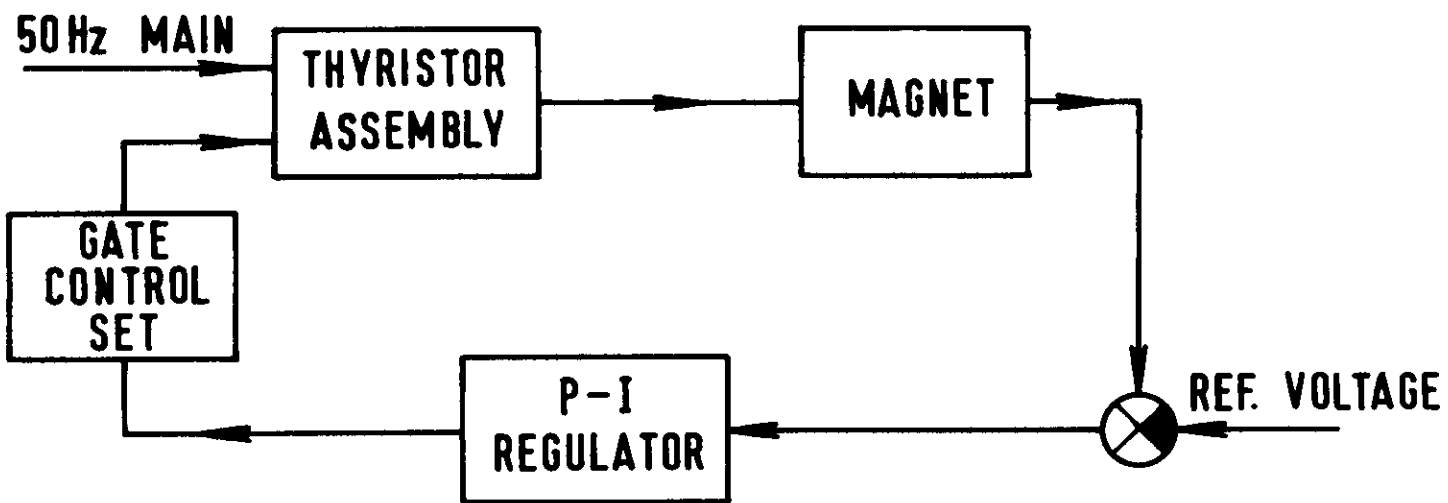

Fig. 1

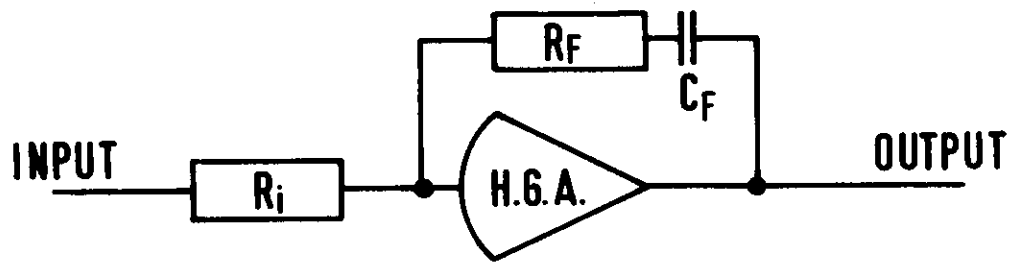

Fig. 2

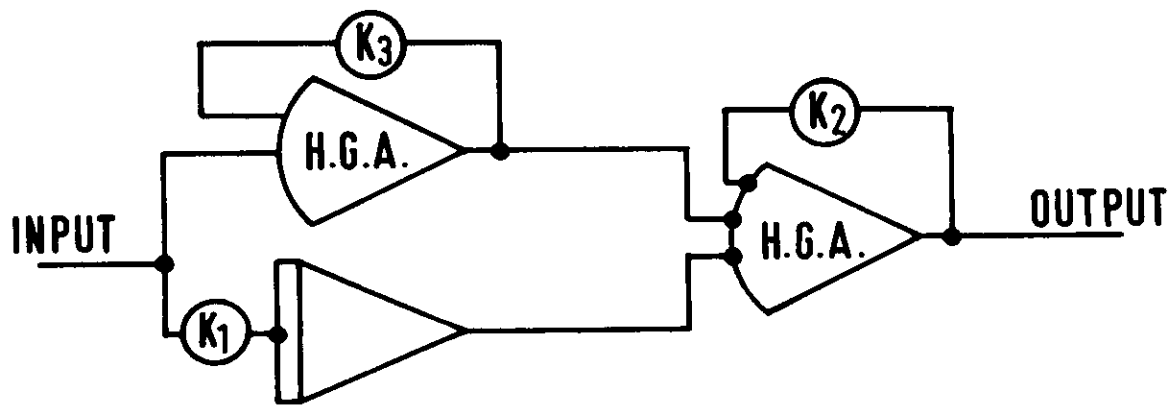
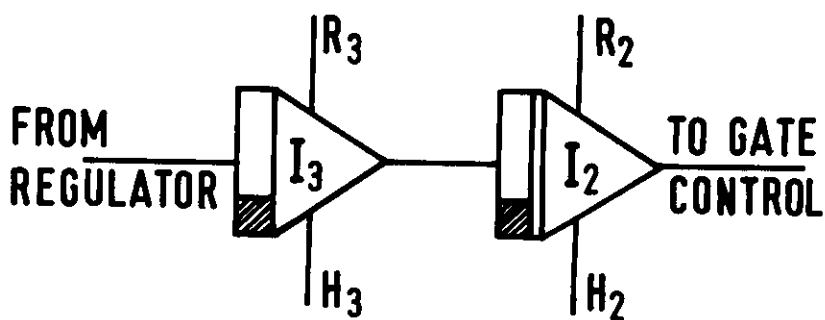
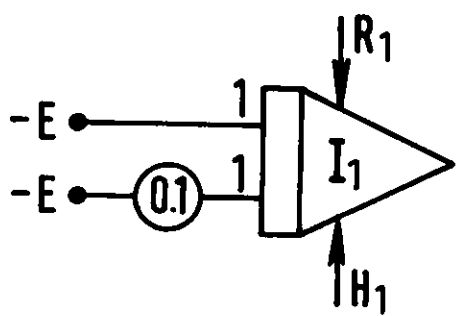
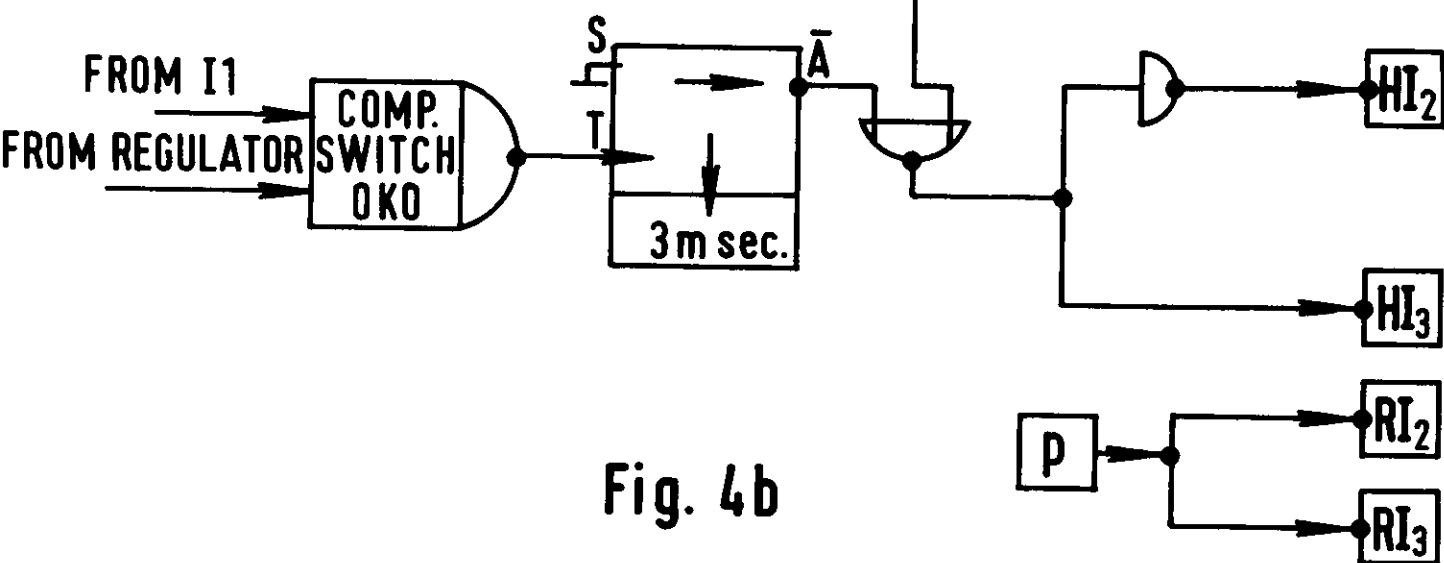
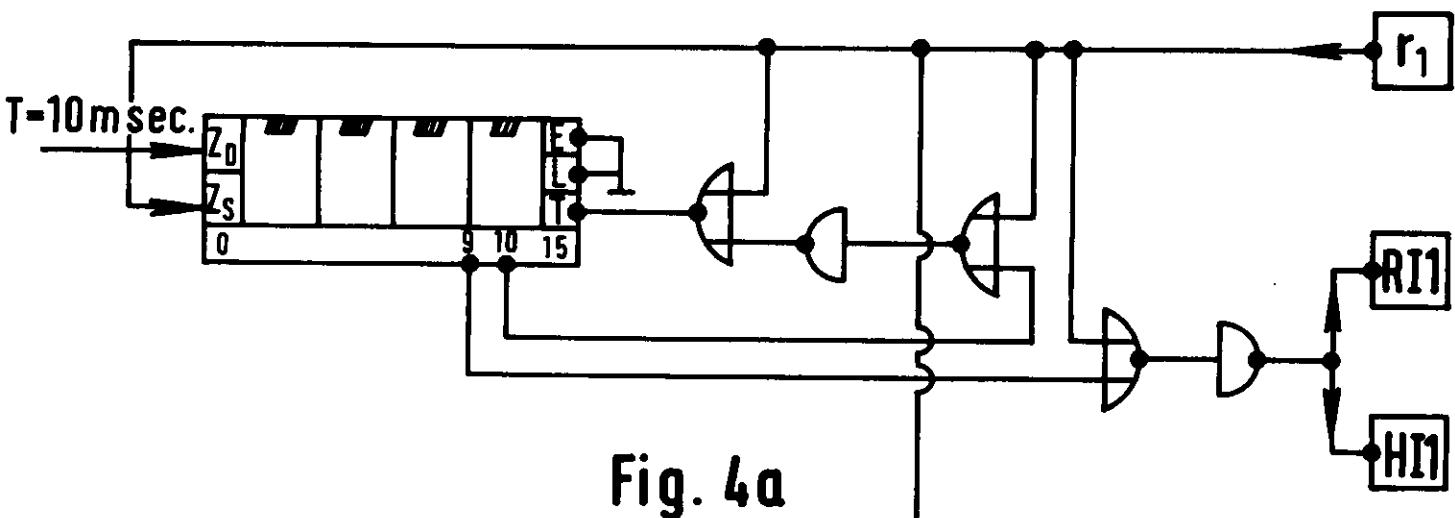

Fig. 3



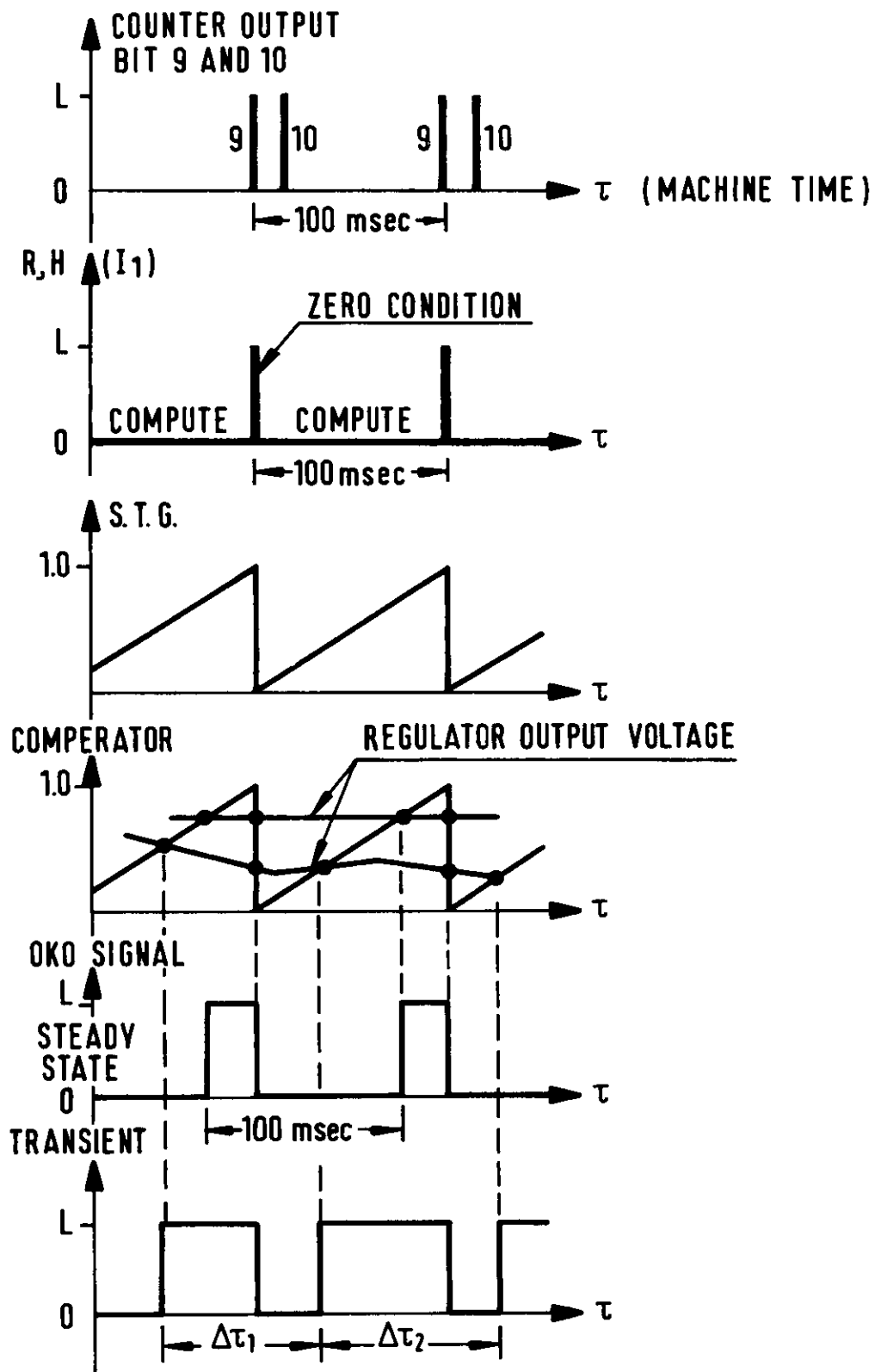

Fig. 4e

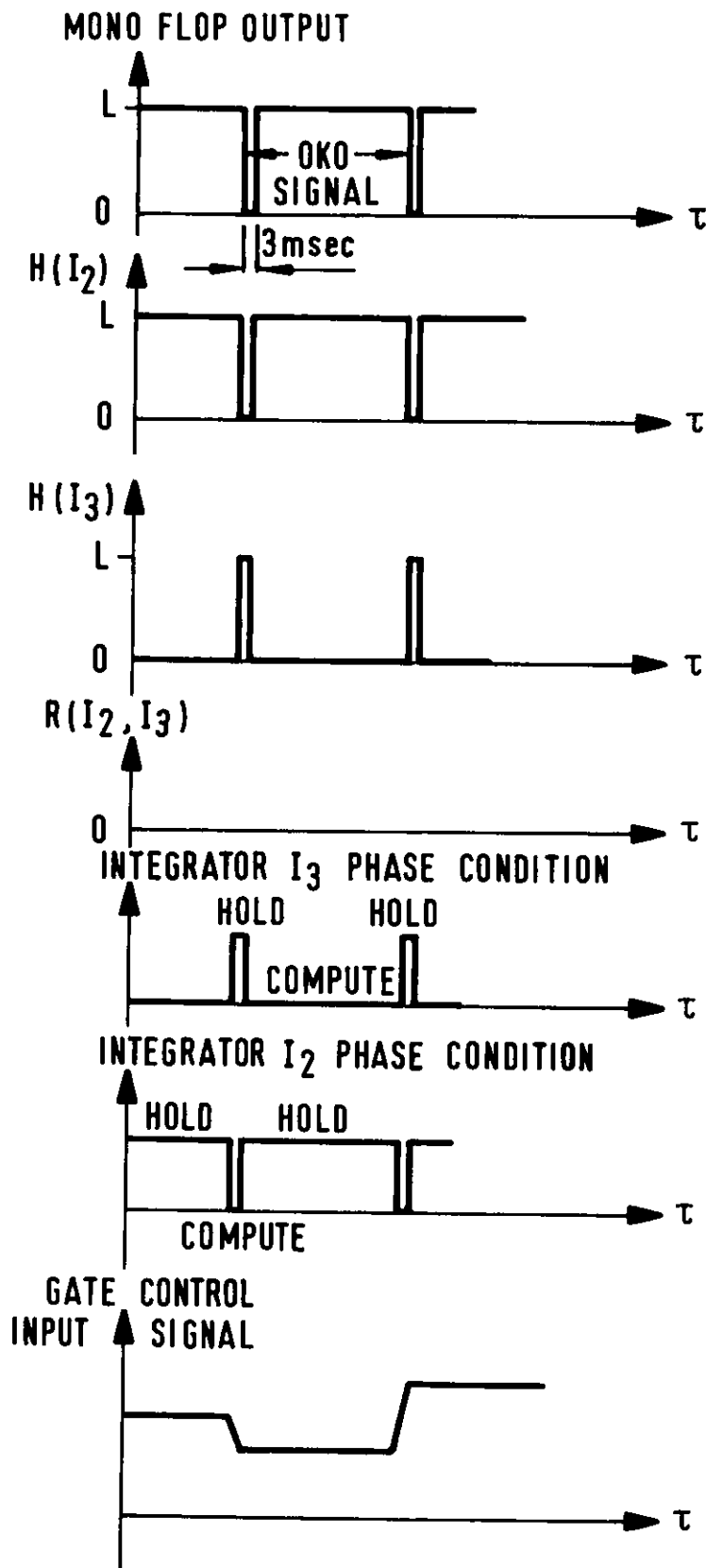

Fig. 4f

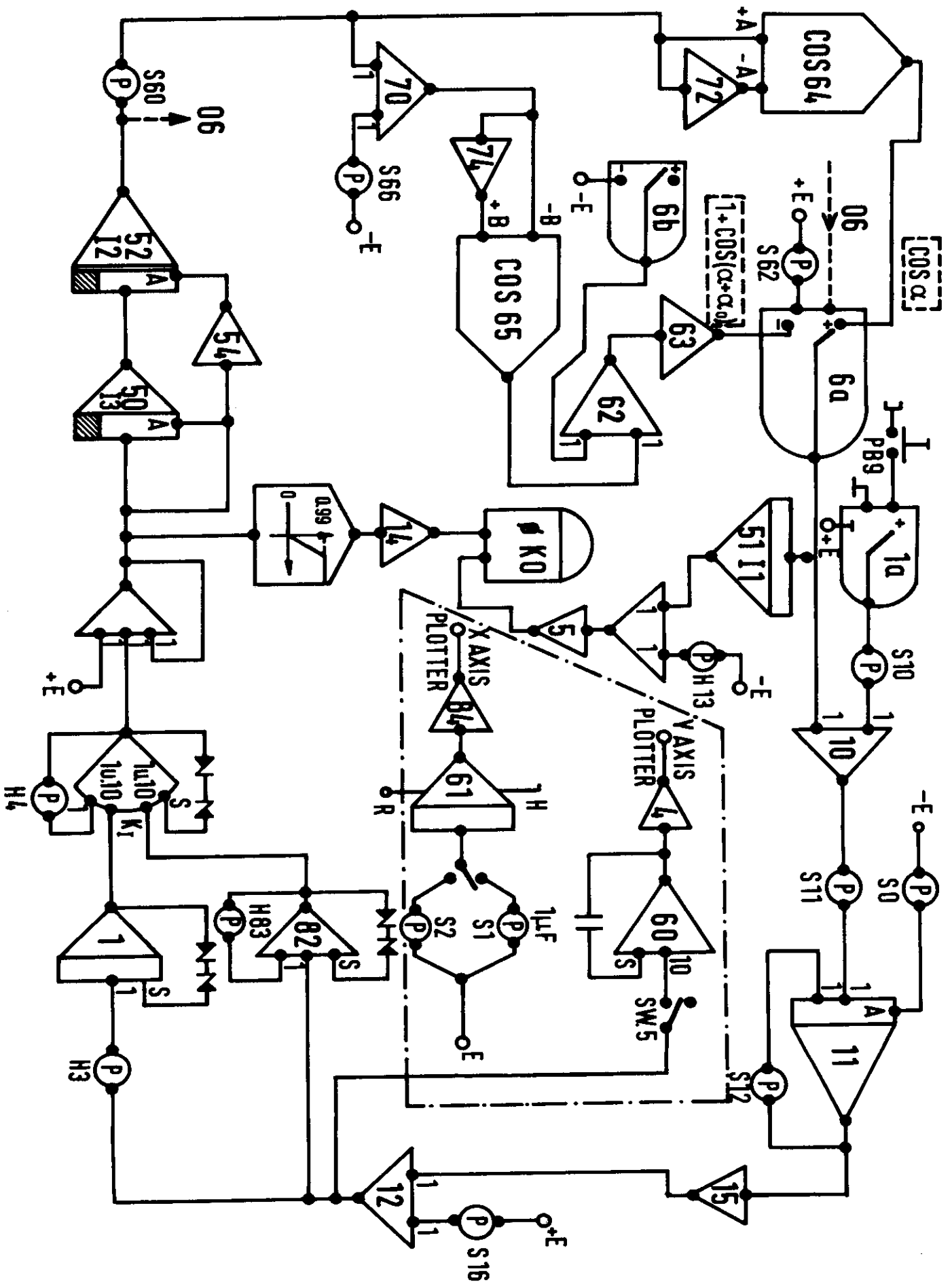

Fig. 5

P → POTENTIOMETER  
 S → SERVO POT.  
 H → HAND POT.

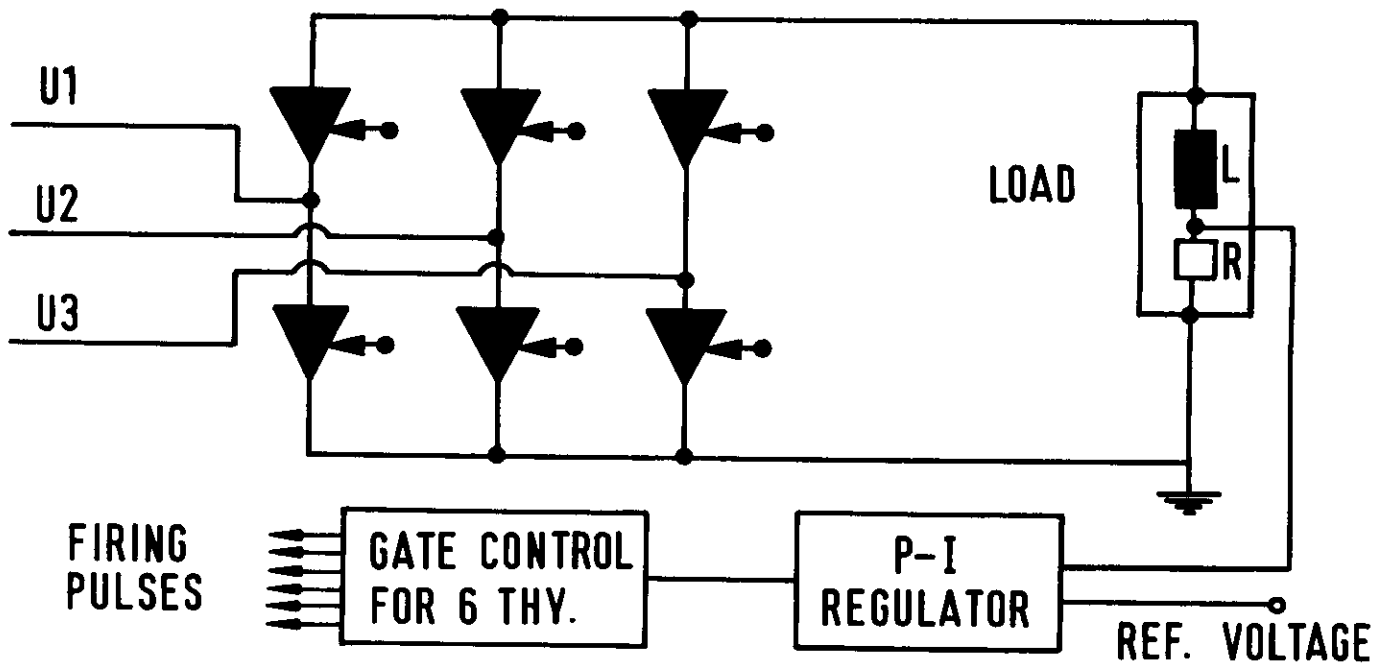

Fig. 6

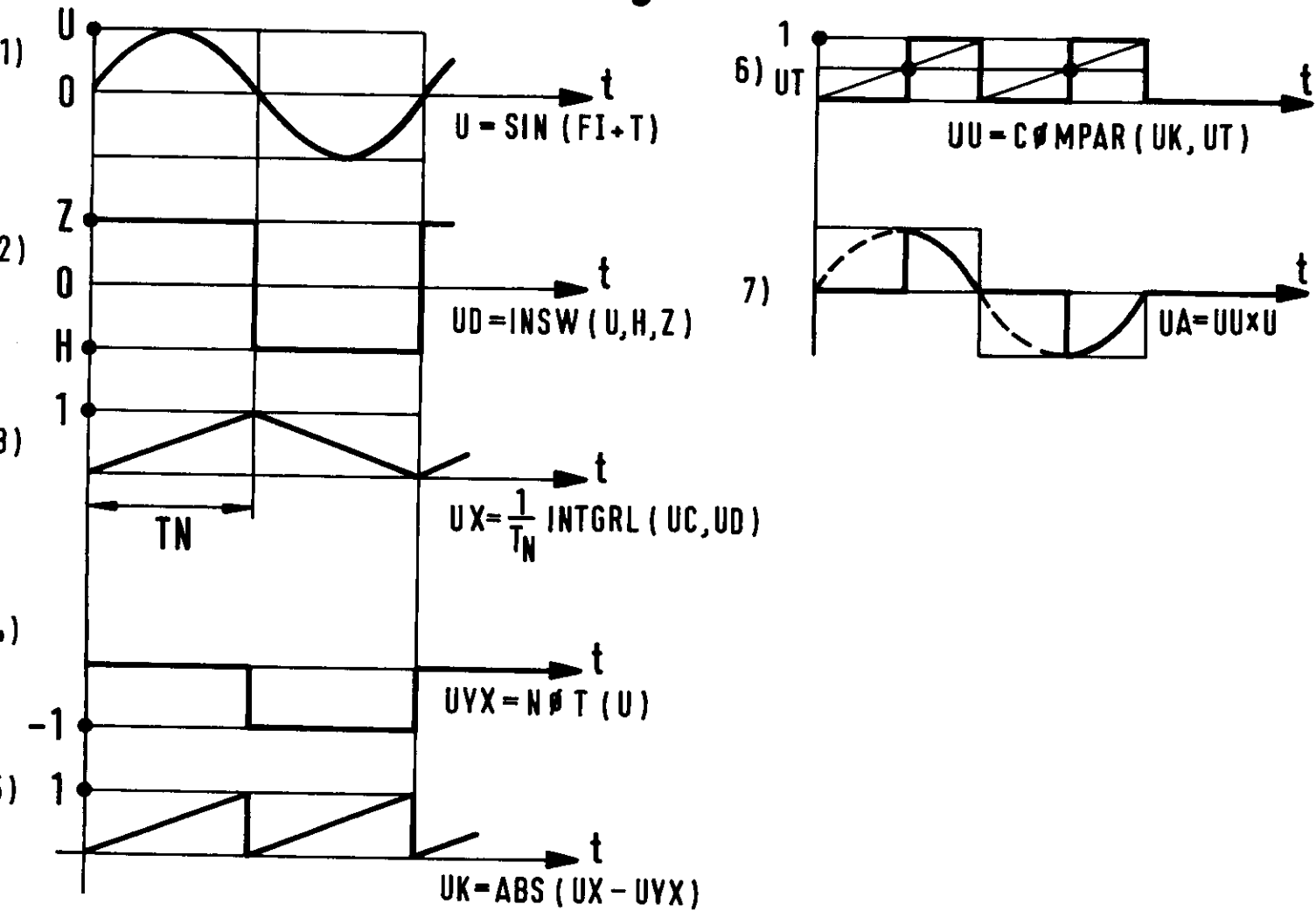

Fig. 7





